

→ **Speedy 360**  
Operating manual



8030

OM 8030\_4.4\_EN (07/2019)  
ENGLISH (Translation)

(AT)

**Trotec Laser GmbH**

☎ +43 7242 239-7070  
service-at@troteclaser.com

(CA)

**Trotec Laser Canada**

☎ +1 800 663 1149-902  
techsupport@troteclaser.ca

(DE)

**Trotec Laser Deutschland GmbH**

☎ +49 89 322 99 65-13  
service-de@troteclaser.com

(GB)

**Trotec Laser UK**

☎ +44 0191 4188 110  
service-uk@troteclaser.com

(MX)

**High Speed Laser Systems S. de R.L. de C.V.**

☎ +52 55 5351-7252  
mexico@troteclaser.com

(US)

**Trotec Laser Inc.**

☎ +1 866 226 8505, Option 2  
support@troteclaser.com

(AU)

**Trotec Laser Pty Ltd**

☎ +61 26413-5904  
service@troteclaser.com.au

(CH)

**Trotec Laser AG**

☎ +41 32387-1611  
service-ch@troteclaser.com  
suisse@troteclaser.com

(ES)

**Trotec Laser España**

☎ +34 93 102 50 50  
soporte@troteclaser.com

(IT)

**Trotec Laser Srl**

☎ +39 02 9475 5447  
supporto.tecnico@troteclaser.com

(NL)

**Trotec Laser B.V.**

☎ +31 850 70 51 55  
support@troteclaser.nl

(ZA)

**Rubber Stamp & Engraving**

☎ +27 875 509-335  
support@trodat.co.za

(BE)

**Trotec Laser België  
Trotec Laser Belgique**

☎ +31 850 70 51 55  
support@troteclaser.nl

(CN)

**Trotec Laser GmbH**

☎ +86 189 500 735 62  
china@troteclaser.com

(FR)

**Trotec Laser France SAS**

☎ +33 1 72 62 20 94  
support.technique@trotec.fr

(JA)

**Trotec Laser Japan Corporation**

☎ Tokyo: +81 42 313 0740  
☎ Osaka: +81 6 6180 2200  
service-jp@troteclaser.com

(PL)

**Trodat Polska Sp. z o.o.**

☎ +48 22 339 35 39  
serwis\_pl@trodat.net

**Trotec Laser GmbH**

Freilingerstraße 99  
4614 Marchtrenk, Austria

Invoice Address:

Linzerstraße 156  
4600 Wels, Austria

Tel.: +43 7242 239-0

**General contact to Technical Support:**

Tel.: +43 7242 239-7000

E-mail: [techsupport@troteclaser.com](mailto:techsupport@troteclaser.com)

**[www.troteclaser.com](http://www.troteclaser.com)**

- Technical Changes    Technical specifications are subject to change without notice.  
Trotec Laser GmbH reserves the right to improve or modify any of the products without prior notice.
- © Copyright            This documentation with all illustrations is intellectual property of Trotec Laser GmbH. The entire documentation is given to the user for personal use only. Reproduction, translation or any distribution to third parties is not permitted without the prior consent of Trotec Laser GmbH. Any breach of law will be prosecuted.

Content

<b>1</b>	<b>General Information.....</b>	<b>8</b>
1.1	Information about this manual.....	8
1.1.1	Storage of the manual.....	8
1.1.2	Complementary documentation.....	8
1.2	Explanation of symbols.....	9
1.3	Liability and warranty.....	10
1.4	Scope of delivery (standard configuration).....	11
1.5	Type plate.....	12
<b>2</b>	<b>Safety.....</b>	<b>13</b>
2.1	General safety notes.....	13
2.1.1	Intended use.....	13
2.1.2	Improper use.....	14
2.1.3	Residual risk.....	14
2.1.4	Machine modification.....	14
2.1.5	Operating modes.....	14
2.1.6	Applicable safety regulations.....	16
2.2	Laser safety.....	17
2.2.1	Laser classification.....	17
2.3	Areas of responsibility.....	18
2.3.1	Responsibilities of the operating company.....	18
2.3.2	Responsibilities of the operating personnel.....	19
2.4	Requirements for operating an service personnel.....	19
2.5	Machine identification (warning and safety stickers).....	20
2.6	Safety devices.....	22
2.7	Technical protective measures.....	23
2.7.1	Main switch.....	23
2.7.2	Key switch.....	23
2.7.3	Temperature sensor.....	23
2.7.4	Emergency stop button.....	24
2.7.5	Interlock safety switches.....	24
2.7.6	Acrylic top lid.....	25
2.7.7	Side cover.....	25
2.7.8	In case of safety device malfunction.....	25
2.8	Secondary (indirect) hazards.....	25
2.8.1	Fire hazard.....	25

2.8.2	Gases, fumes and dust.....	26
2.8.3	Reflection through materials.....	27
2.8.4	Information about damaged optics.....	28
2.8.5	Protective measures for damaged optics.....	29
<b>2.9</b>	<b>In case of emergency.....</b>	<b>30</b>
<b>3</b>	<b>Technical Data.....</b>	<b>31</b>
3.1	Dimensions and weight.....	31
3.2	Electrical requirements of the machine.....	32
3.3	Exhaust system requirements.....	33
3.4	Computer requirements.....	35
3.5	Materials.....	36
<b>4</b>	<b>Machine overview.....</b>	<b>40</b>
4.1	General overview.....	40
4.2	Front door.....	41
4.3	Tables (multifunctional table concept).....	41
4.3.1	Additional tabletops.....	43
4.3.2	Table placement.....	44
4.4	Lens(es).....	45
4.5	Nozzles.....	46
<b>5</b>	<b>Transport.....</b>	<b>47</b>
5.1	Safety notes.....	47
5.2	Delivery state.....	47
5.3	Temperature and humidity.....	49
5.4	Required tools for unloading and transport.....	49
5.5	Place of storage.....	49
5.6	Transport inspection and reporting of defects.....	50
5.7	Unpacking the machine.....	51
5.8	Relocation of the machine.....	52
<b>6</b>	<b>Setup and installation.....</b>	<b>53</b>
6.1	For your safety.....	53
6.2	Temperature and humidity.....	53
6.3	Space requirements.....	54
6.4	Setup.....	54
6.5	Connections.....	55
6.5.1	Mains connection.....	56
6.5.2	Connection the PC.....	56
<b>6.6</b>	<b>Connection of additional components.....</b>	<b>57</b>
6.6.1	Connecting an exhaust system from Trotec.....	57

<b>7</b>	<b>Operation.....</b>	<b>58</b>
7.1	Before commissioning.....	58
7.2	Software.....	58
7.3	Power On/Off.....	58
7.4	Control panel.....	61
	7.4.1 Keypad.....	61
7.5	Lense placement.....	67
7.6	Focusing methods.....	68
	7.6.1 Focus tool.....	69
	7.6.2 Sonar Technology™.....	70
	7.6.3 Software focus.....	71
	7.6.4 Light barrier focus.....	72
7.7	Rotary attachment (option).....	73
	7.7.1 Installation and commissioning of the rotary attachment.....	73
	7.7.2 Mounting the work piece in the rotary attachment.....	74
	7.7.3 Engraving process.....	75
<b>8</b>	<b>Maintenance.....</b>	<b>76</b>
8.1	Safety notes.....	76
8.2	Maintenance schedule.....	77
8.3	Cleaning.....	78
	8.3.1 Machine.....	78
	8.3.2 Exhaust box.....	79
	8.3.3 Optics in general.....	80
	8.3.4 Lens.....	80
	8.3.5 Mirror.....	82
	8.3.6 Ultrasonic sensor (Option Sonar Technology™).....	83
<b>9</b>	<b>Troubleshooting.....</b>	<b>84</b>
9.1	Error, cause and remedy.....	84
	9.1.1 How to create a service file.....	86
<b>10</b>	<b>Contact details.....</b>	<b>87</b>
<b>11</b>	<b>Disassembly.....</b>	<b>88</b>
<b>12</b>	<b>Disposal.....</b>	<b>89</b>
<b>13</b>	<b>Appendix.....</b>	<b>90</b>

### 1 General Information

For reasons of better legibility, gender-neutral form of address (e. g. "he/she") are not used in the operating manual. It is expressly stated that in all text passages where natural persons or groups of persons are mentioned, people of both sexes are always meant.

#### 1.1 Information about this manual

**Before beginning any work on the machine, read this manual completely and carefully.  
Keep the manual for further consultation close to the machine.**

This manual describes how to operate the machine properly and safely. Be sure to follow the safety instructions given here, as well as any local accident prevention regulations and general safety regulations applicable to the field of usage. Before beginning any work on the machine, ensure that the manual, in particular the chapter entitled "Safety Information" and the respective safety guidelines, has been read in its entirety and fully understood.

##### 1.1.1 Storage of the manual

This manual is an integral part of the machine and must therefore be kept in the direct vicinity of the machine and be accessible at all times.

##### 1.1.2 Complementary documentation

Complementary documentation can be found on the supplied DVD.

#### **Software manual**

Trotec Laser GmbH JobControl®



## 1.2 Explanation of symbols

Important technical safety notes and instructions in this manual are indicated by symbols. It is important to observe and follow these notes and instructions on workplace safety. Avoid accidents, personal injury and material damage to property by acting with extreme caution.



### **Danger**

This symbol indicates an imminently hazardous situation which, if not avoided, will result in death or serious injury.



### **Warning**

This symbol indicates a potentially hazardous situation which, if not avoided, could result in death or serious injury.



### **Warning Current**

This symbol warns of potentially dangerous situations related to the electric voltage. Failure to observe the safety instructions leads to risk of serious injury or death. Particular care should be taken during maintenance and repair work.



### **Warning Laser**

This symbol warns of potentially dangerous situations related to the laser beam. Failure to observe the safety instructions leads to risk of serious injury.



### **Caution**

This symbol indicates a potentially hazardous situation which, if not avoided, could result in minor or moderate injury.



### **Notice**

This symbol indicates potential risks of damage to the supported product (or to property). In addition, non-observance may result in damage, malfunction or failure of the machine.



### **Information**

This symbol indicates tips and information which must be observed for efficient and trouble-free handling of the product.



### **Disposal**

This symbol indicates notes regarding the professional disposal of the product or accessories.

### 1.3 Liability and warranty

Warranty periods specified in the manufacturers "warranty terms and conditions" shall be binding for the buyer. If no warranty periods are specified, the general terms and conditions of sale, delivery and payment apply.

All information, illustrations, tables, specifications and diagrams contained in this operating manual have been carefully compiled according to the current state of technology. No liability is accepted with regard to errors, missing information and any resulting damage or consequential loss.

Strict compliance with the safety procedures described in this operating manual and extreme caution when using the equipment are essential for avoiding and reducing the possibility of personal injury or damage to the equipment. The manufacturer shall not be liable for any damage and or faults resulting from nonobservance of instructions in this manual.

Nonobservance of the operation, maintenance and service instructions described within this manual absolves Trotec Laser GmbH from any liability in case of a defect.

Furthermore, Trotec Laser GmbH shall accept no liability whatsoever for damage caused by the use of non-original parts and accessories.

Additionally, Trotec Laser GmbH shall not be held responsible for any personal injury or property damage, of an indirect or specific nature, consequential loss, loss of commercial profits, interruption to business, or loss of commercial information resulting from use of the equipment described in this manual.

It is strictly prohibited to make any alterations, to prepare translations, decompile, disassemble, reverse engineer or copy the software.

Trotec Laser GmbH reserves the right to update any of the information, illustrations, tables, specifications and diagrams contained in this operating manual with regard to technical developments at any time without notice.

#### 1.4 Scope of delivery (standard configuration)

1. Laser machine
2. DVD (with laser software, printer driver and operating manual)
3. Focusing tool(s) (according to lens order)
4. Cleaning kit for optics
5. Nozzles (2 pcs.:  $\varnothing 3$  and  $\varnothing 7$ )
6. Lens: 2.0" (CO<sub>2</sub>), 3.2" (fiber), 2.85" (flexx)
7. Ferromagnetic engraving table of multifunctional table concept (according to order)
8. Allen key kit (8-part)
9. Open-end wrench
10. Power cord 5 meters (according to order)
11. USB computer connection cable
12. RS232 cable (according to order)
13. Exhaust connection cable (according to order)

The actual scope of delivery may be different, depending on the special model, additional order options or newest technical changes.

## 1.5 Type plate

The type plate with the CE mark is located on the rear of the machine.

Enter the serial number, model and year of manufacture into your manual and always refer to them when contacting us for enquiries, troubleshooting or ordering of replacement parts.

Serial number:	
Model:	
Year of manufacture:	

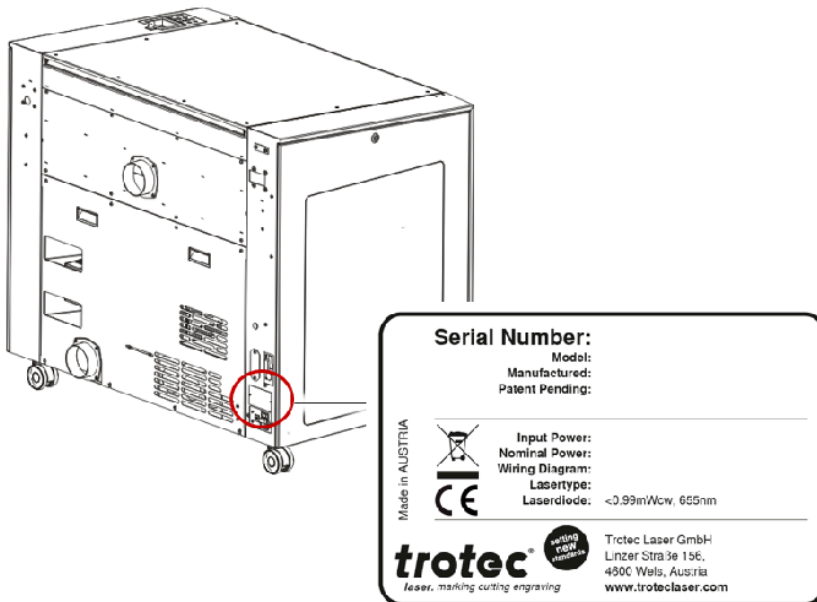

## 2 Safety

### TO AVOID POSSIBLE HARM READ AND FOLLOW THESE INSTRUCTIONS.

The machine is built at the time of its development and production according to applicable, established technical rules and is considered to be safe to operate.

Dangers can be caused by the machine if the machine:

- is operated by unqualified personnel,
- the personnel have not been trained,
- the machine is used improperly or not as intended,
- or if the machine is used for other intended purposes.

This chapter provides an overview of all important safety aspects that are necessary for optimum protection of persons and safe and trouble-free operation of the machine. Other chapters of this manual contain specific safety notes for the avoidance and prevention of hazards.

### 2.1 General safety notes

#### 2.1.1 Intended use

**The machine described in this manual is intended exclusively for laser engraving and laser cutting, of material according to the intended use of the machine using the supplied software.**

For material details see chapter "Materials" or contact your local Trotec representative, or your local Technical Support.

The system must be operated, maintained and repaired only by trained personnel familiar with the designated field of use and the dangers of the machine.

Operate the machine only in technically flawless condition and when it fully complies with the EC Machinery Directive.

The intended use of this machine also includes that all personnel involved in installation, set-up, operation maintenance and repair of the machine must have read and understood the Manual and in particular the "Safety" section, and comply with the instructions.

#### **Organisational measures:**

- Personal protective equipment
- Inspection of the laser protection wall
- Laser safety instructions/laser safety training
- Monitoring by Laser Safety Officer

### 2.1.2 Improper use

Use of the machine for any purposes other than those intended or described in the present manual is regarded as improper and therefore prohibited. Trotec Laser GmbH will not accept any liability for damage caused by improper use. The risks in case of improper use are exclusively borne by the user.

Non-observance of the operation, maintenance and service instructions described within this manual absolves Trotec from any liability in case of a defect.

### 2.1.3 Residual risk

Even if all safety regulations are observed, a residual risk remains during operation.

### 2.1.4 Machine modification

It is strictly prohibited to alter, refit or modify the machine in any way without the express consent of the manufacturer.

Likewise, it is strictly prohibited to remove, bridge or bypass any safety devices. Operating conditions and connection and setup values stated in the data sheet must be complied with at all times.

Operation of the system is permitted only with original parts and accessories by the manufacturer. Use of third-party parts affects machine safety.

### 2.1.5 Operating modes

#### Normal operation

**For normal operation the following conditions must be met:**

- Intended use of the machine (see chapter "Intended use").
- Operation of the machine only by trained personnel.
- Full functional and mounted safety devices.
- Machine must be in technically flawless condition.
- Only non-metal and material according to the intended use of the machine must be used.



#### Notice

During normal operation it is not necessary to wear safety glasses.

### **Service operation**

Service activities may be carried out only by authorized, trained service technicians. If side panels as well as covers get removed and safety devices get bypassed, it can lead to direct and indirect scattered radiation. The service operation is therefore declared as laser class 4 (US: class IV) and proper precautions need to be taken (see "Laser classification").

## 2.1.6 Applicable safety regulations

The following directives and guidelines must be observed to avoid hazards when operating Trotec laser systems:

### Guidelines/Regulations

2006/42/EC	EC Machinery Directive
2014/30/EU	EMC Guideline

### Applied harmonized standards

EN ISO 12100:2011-03	Safety of machinery - General principles for design - Risk assessment and risk reduction.
IEC 60825-1:2014, EN 60825-4:2011	Safety of laser products - Part 1: Equipment classification and requirements.
IEC 60204-1:2005	Safety of machinery - Electrical equipment of machines - Part 1: General requirements.
ISO/DIS 11553-1:2009-03	Safety of machinery - Laser processing machines - Part 1: General safety requirements.
IEC 61000-6-4:2007-02	Electromagnetic compatibility (EMC) - Part 6-4: Generic standards - Emission standard for industrial environments.
ISO 13857:2008	Safety of machinery - Safety distances to prevent hazard zones being reached by upper and lower limbs.
EN 55011+A1:2016-05	Industrial, scientific and medical equipment - Radio-frequency disturbance characteristics - Limits and methods of measurement.



### Notice

#### Safety norms and regulations.

The general guidelines and directives listed within this manual may differ according to locality, region or country.

Therefore, always observe the directives as well as the regulations of the institutions for statutory accident insurance association applicable to you. The operator is responsible for fulfilling all safety requirements, as Trotec Laser GmbH has no influence on the proper use of the machine.

Observe the official regulations for your business location in accordance with the applicable local legal regulations (on accident prevention regulations or employee protection), e.g. DGUV regulation 11 for Germany.



## 2.2 Laser safety

### 2.2.1 Laser classification

The laser safety class indicates the risk potential from accessible laser radiation.

The laser system is a Class 2 (US: Class II) laser marking system as per IEC 60825-1 "Safety of Laser Products".



#### **Warning Laser**

##### **Laser radiation of Class 2 (US: class II)**

For Class 2 (US: class II) laser is short term exposure (up to 0.25 seconds) harmless to the eyes and can therefore be operated without additional protective measures. However it can cause irritation of the eyes if the natural avoidance reaction (staring into the laser beam deliberately) or eyelid closure reflex is suppressed.

- Do not suppress the eyelid closure reflex.
- Do not stare directly into the laser beam.
- Close eyes, turn away.
- Never look at the laser beam directly with an optical instrument, e.g. a lens.

#### **Class 2 (US: class II)**

The accessible laser radiation of Class 2 (US: Class II) laser systems does not pose any hazard for the skin. Diffuse reflections as well as any short-term irradiation of the eyes (exposure time max. 0.25 seconds) also pose no risk due to the low output power.

However, it is possible to suppress the natural eyelid closure reflex and stare into the class-2 laser beam for a time long enough for the eyes to get injured.

### 2.3 Areas of responsibility

#### 2.3.1 Responsibilities of the operating company

**The operator has the following responsibilities:**

- It is the responsibility of the operator to comply with the national official and statutory regulations for the operation of a class 4 (US: class IV) laser system or laser system with a build in laser source of class 4 (US: class IV).
- In addition to the safety notes and instructions stated in this manual, consider and observe the local accident prevention regulations and general safety regulations that apply at the operation site of the machine.
- A CO<sub>2</sub> fire extinguisher must always be at hand, as the laser beam can ignite flammable materials.
- If the machine is used industrially, the operator is subject to the legal obligations concerning industrial safety.
- All personnel involved in installation, set-up, operation, maintenance and repair of the machine must have read and understood this manual and in particular the "Safety" section. The personnel must be trained and informed about all the functions, potential dangers and safety issues of the machine on a yearly basis.
- The user is recommended to prepare company internal instructions considering the occupational qualifications of the personnel employed in each case, and the receipt of the instruction/this manual or the participation in the introduction/training should in each case be acknowledged in writing.
- Keep the manual in the immediate vicinity of the machine so that it is accessible at all times to all persons working on or with the machine.
- Authority for the individual activities relating to the application of the machine (e.g. installation, operation, maintenance and cleaning) must be clearly defined and observed, so that no unclear competencies result under the aspect of safety. This applies in particular to work to be performed on the electrical equipment that may only be performed by qualified specialists.
- Maintenance and repair work as specified in the manual must be carried out regularly.
- For all activities concerning installation, set-up, start-up, operation, modifications of conditions and methods of operation, maintenance, inspection and repair, the switch-off procedures that may be provided in the manual must be observed.
- Provide appropriate personal protection equipment (e.g. protective goggles according to wavelength and laser power).
- The operator is responsible for the safety-related state of the machine.
- Do not store any flammable materials in the working area or in the immediate vicinity of the device. Particularly, residues of processed materials have to be removed to prevent any fire hazard.
- The operator must ensure cleanliness and accessibility at and around the machine by corresponding instructions and controls.

### 2.3.2 Responsibilities of the operating personnel

The operating personnel has the following responsibilities:

- Always wear personal protective equipment.
- It is the duty of the operating personnel to check the machine before start of work for externally visible damage and defects, and to immediately report any changes that appear (including behavior during operation) that may affect the safety of the machine. It must be made sure that the machine is operated only in perfect condition.
- The machine must not be left unattended while it is operating (supervised operation).
- Switch off the machine described herein at the main switch for periods of non-use.
- Operate the machine described here only with a lens in place. A missing lens may cause the unfocused laser beam to be reflected out of the housing.
- Stop this machine immediately in case of failure.
- No working methods are permitted that affect the safety of persons or of the machine.
- Always keep clean the machine and its components such as lens and mirrors.



#### Caution

The adjustment of the beam path may only be carried out by service personnel of Trotec Laser GmbH.

### 2.4 Requirements for operating an service personnel

The requirements for the operating and service personnel are:

- The personnel must have read and understood this manual and in particular the "Safety" section.
- The personnel must not be under the influence of drugs, alcohol or reactivity affecting medication when working on or with the machine.
- The personnel must be familiar with using the CO<sub>2</sub> fire extinguisher.
- The personnel must be trained in order to be qualified to operate the machine. If the personnel lack the necessary knowledge for working on or with the machine, they must first be trained and note down the training in the training verification form.

Activity	Intended user group	Definition
Control/operation/other activities (e.g. troubleshooting, maintenance)	Qualified personnel or Trotec service technicians	Qualified personnel are those who can judge the work entrusted to them and detect potential risks based on their occupational training, knowledge and experience as well as their understanding of the relevant regulations.

## 2.5 Machine identification (warning and safety stickers)

The warning and information labels are attached in the positions of the machine that could represent a source of danger during set-up and operation. Therefore, pay attention to the information on the labels.



### Caution

#### Lost or damaged warning and safety stickers.

If any warning and safety stickers are lost or damaged, the user is not able identify risks anymore, and there is danger of injury.

- Replace lost or damaged labels immediately.
- Contact your Trotec Laser GmbH dealer for details.

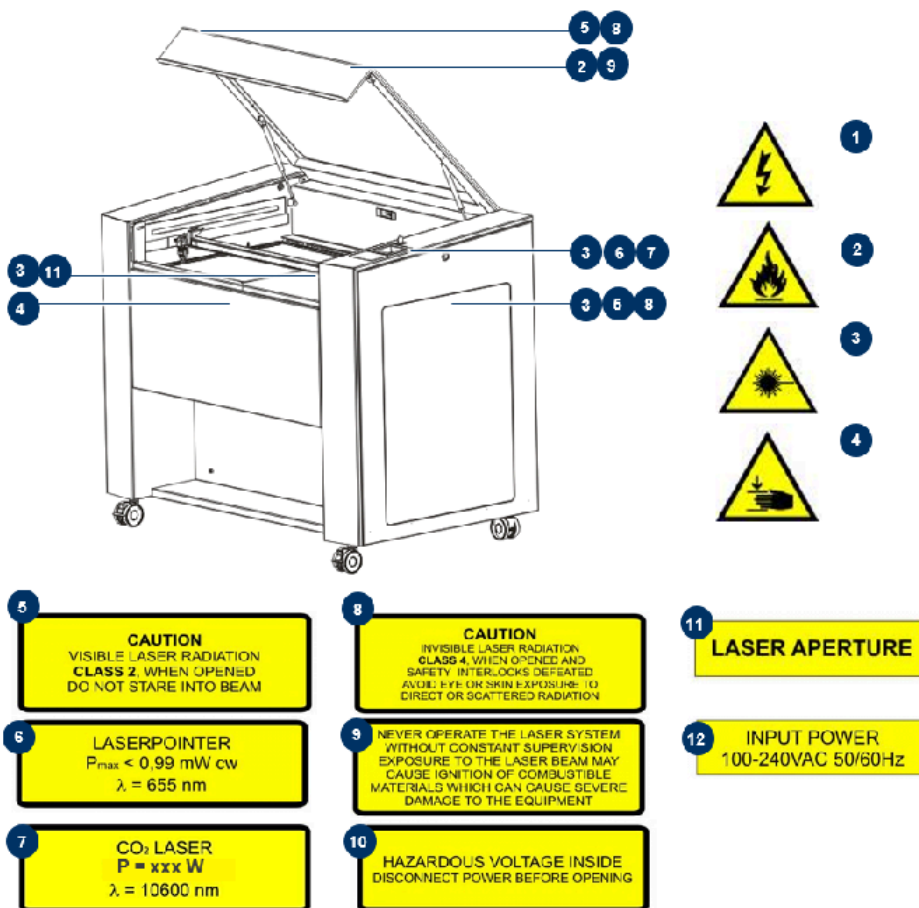

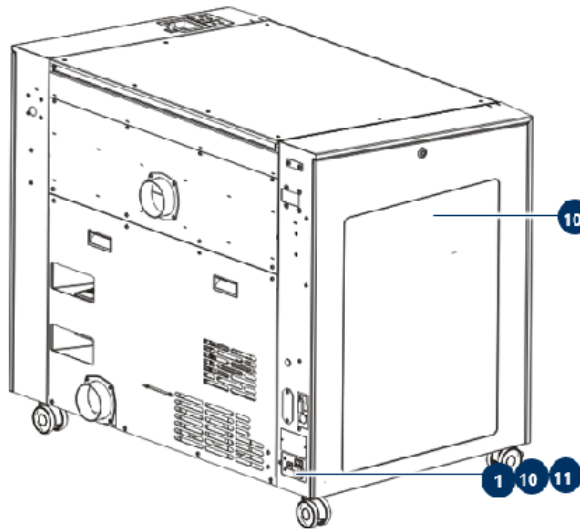

**5**  
**CAUTION**  
VISIBLE LASER RADIATION  
**CLASS 2**, WHEN OPENED  
DO NOT STARE INTO BEAM

**6**  
**LASER POINTER**  
 $P_{max} < 0,99 \text{ mW cw}$   
 $\lambda = 655 \text{ nm}$

**7**  
**CO<sub>2</sub> LASER**  
**P = xxx W**  
 $\lambda = 10600 \text{ nm}$

**8**  
**CAUTION**  
INVISIBLE LASER RADIATION  
**CLASS 4**, WHEN OPENED AND  
SAFETY INTERLOCKS DEFEATED  
AVOID EYE OR SKIN EXPOSURE TO  
DIRECT OR SCATTERED RADIATION

**9**  
**NEVER OPERATE THE LASER SYSTEM**  
WITHOUT CONSTANT SUPERVISION  
EXPOSURE TO THE LASER BEAM MAY  
CAUSE IGNITION OF COMBUSTIBLE  
MATERIALS WHICH CAN CAUSE SEVERE  
DAMAGE TO THE EQUIPMENT

**10**  
**HAZARDOUS VOLTAGE INSIDE**  
DISCONNECT POWER BEFORE OPENING

**11**  
**LASER APERTURE**

**12**  
**INPUT POWER**  
100-240VAC 50/60Hz

2.6 Safety devices



**Warning**

**Danger from laser beam.**

Safety and protection devices that are not installed or are not fully functional can lead to bodily injury and material damage.

- Do not remove, modify or deactivate the interlock safety switches or protective covers on the machine. Safety and protection devices must be fully functional at all times.
- In case of assumed or presumed damage of safety devices, disconnect the machine from the mains.
- Damaged safety and protection devices need to be replaced by a Trotec technician immediately.

The machine is equipped with following safety devices:

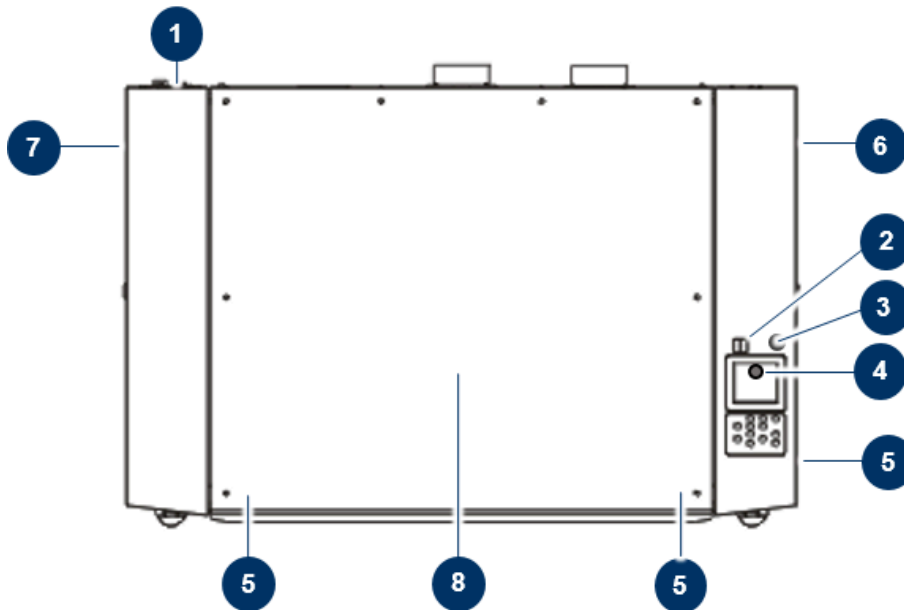

No.	Description	No.	Description
1	Main switch	5	Interlock safety switch
2	Emergency stop button (only with temperature sensor option)	6	Side panel right (with interlock safety switch)
3	Temperature sensor reset button (only with temperature sensor option)	7	Side panel left (with interlock safety switch)
4	Key switch	8	Acrylic top lid

## 2.7 Technical protective measures

### 2.7.1 Main switch

Pressing the main switch on the backside of the machine to disconnect the machine from the mains power supply.

### 2.7.2 Key switch

Turning the key switch counterclockwise powers off the motor, laser source and electric system. Through the key switch, operation by non-authorized personnel can be prevented.

### 2.7.3 Temperature sensor

The temperature sensors ensure reliable temperature monitoring of the interior of the machine and are available as additional option.

If a preset temperature value is exceeded, an acoustic alarm continuously sounds to warn the operator of abnormal temperature trends during processing.



#### **Warning**

##### **Fire hazard**

The acoustic alarm upon startup of the machine indicates that the sensors are operating properly. However, the sensors do not guarantee fire prevention.

- The unit must not operate unattended despite the integrated temperature sensors.
- If the acoustic alarm does not sound when the machine is switched on, check the functionality of the sensors.
- In case of questions, contact our experienced Technical Support in your local area.

#### **Functional test of the temperature sensors**

When the machine with the temperature sensor option is activated, all sensors are checked for proper function, and you will hear an acoustic signal.

If you do not hear an acoustic signal, please check the cables, connections, etc., or contact your local Technical Support.

### Temperature sensor alarm acknowledgement

Press the temperature sensor reset button to acknowledge the alarm.

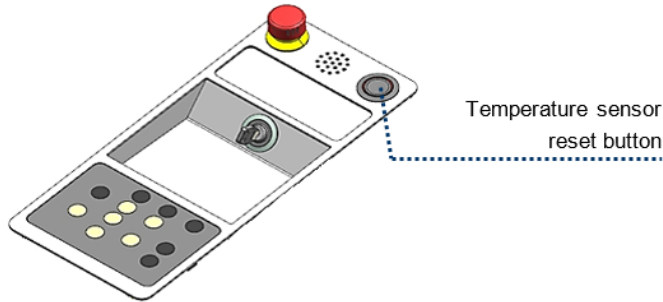

### 2.7.4 Emergency stop button

The Emergency stop button, which is located above the operation panel, is present only if the machine is equipped with an optional temperature sensor.

When pressing an Emergency stop button, the electric circuit immediately shuts off.

The laser beam is interrupted, and all movements are stopped.

#### The function of the Emergency stop button is:

- Firstly: To prevent any risks to the operating personnel.
- Secondly: To avoid any damage to/destruction of the machine/material.

### Emergency stop button acknowledge



1. Turn the Emergency stop button counterclockwise to unlock it (green marker is visible).
2. Reboot the laser system to acknowledge the laser fault.

### 2.7.5 Interlock safety switches

Interlock safety switch query the closed status of the acrylic top lid, side panels and front door. If the safety devices are open or not present, the laser cannot be operated. However, the pilot laser stays active.



### 2.7.6 Acrylic top lid

The type of acrylic top lid depends on the laser type. It protects the operator from uncontrolled emission of laser radiation.

### 2.7.7 Side cover

The side panels protect from laser light and must always be closed and properly attached.

### 2.7.8 In case of safety device malfunction

Actual or presumed damage to the safety devices can cause injury or damage. Following measures must be carried out.

1. Press the emergency stop button.
2. Disconnect the machine from the mains.
3. Contact our Technical Support in your local area.

## 2.8 Secondary (indirect) hazards

### 2.8.1 Fire hazard



#### Warning

#### Fire hazard

Fire hazard from gas and processing of inflammable materials.

- Do not operate the device without supervision.
- Keep CO<sub>2</sub> fire extinguisher ready at hand in the immediate vicinity of the device.

If a main laser beam comes into contact with inflammable material, e.g. paper, the latter may ignite, quickly leading to fire. Therefore, before switching on the laser and after deactivating the Standby-mode you must make sure that there is no inflammable material in the path of the laser beam.

Furthermore, gases formed beneath the material being processed may ignite, especially if the extraction requirements are not met.

The risk of flaming is increased in case of insufficient care and cleaning as well.

Additionally, regularly control the air cooling system on your laser. In particular, the filters and ventilators should be checked regularly for proper function to avoid defects caused by overheating.

### 2.8.2 Gases, fumes and dust

Depending on the materials being processed and the parameters selected, laser processing may generate gases, fumes, aerosols or dust. Depending on the material, such by-products may be toxic. In individual cases, the reaction products may be electrically conductive dusts. If these enter electric systems, short-circuiting with personal injury and property damage may occur.

The operator is responsible for ensuring presence of a suitable extraction system and compliance with the relevant guidelines in order to protect persons and the environment. The guideline VDI 2262 1-3 "Workplace air" provides, among other things, additional remarks.

The operator must also ensure that gases, fumes or dust do not settle on the processing lens. Any dirt accumulating on the processing lens can lead to loss of performance, poor processing results and damage to the device.

### 2.8.3 Reflection through materials



#### Warning

##### Danger from laser beam.

Invisible laser radiation of reflecting materials can cause serious injury or material damage.

- Only material according to the intended use of the machine may be used.
- Do not use material with high reflecting surfaces such as aluminum, chromium, precious metals, metal foils, stainless steel, brass, copper and titanium.
- Take special care with surfaces formed convex and concave.
- Do not leave or put objects on the work surface/working area.

#### Laser beam reflection

The reflecting law is valid for the reflection of the laser radiation: **Angle of incidence = failure corner**

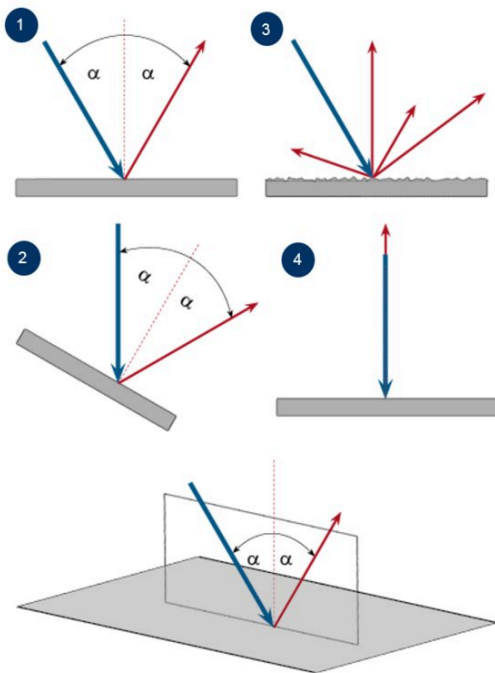

No.	Description
1	Directed reflection: Reflected ray on smooth surface.
2	Directed reflection: Reflected ray on sloping surface.
3	Diffuse reflection: Reflected ray on rough surface.
4	Directed reflection: Horizontally reflected ray on smooth surface.

#### 2.8.4 Information about damaged optics



##### Warning

##### Damage to optics.

Soiled optics absorb laser radiation and can thus be destroyed. Broken or damaged lenses as well as thermal decomposition of lenses release particles which cause serious damage to the health.

- The passive reflectors and optics in the area of the laser beam guidance should be cleaned regularly.
- Special care is required when handling, attaching and cleaning these elements.
- Do not exert non-uniform pressure.
- Do not use tools or hard objects to clean the surface.
- Never touch the optics with your bare fingers.
- Never use cleaning tissues twice.
- When lenses get broken, damaged or thermal decomposed follow the protective measures.
- Disposal according to regulations and laws valid in the user's country.
- **Lenses with scratches or lenses with penetrations must not be used anymore!**

##### Scatched or destroyed lens surface

Be aware that scratches in the coating may release small quantities of thorium, which may be harmful upon inhalation or swallowing.

##### Thermal decomposition

Upon thermal decompositions, vapors of selenium oxide and zinc oxide are formed. Upon inhalation or swallowing there is danger of poisoning. Indicators for thermal decomposition of ZnSe include deposits in the form of red or white powder and an unpleasant odor.

##### Broken lenses

When optical components of zinc selenide (ZnSe) are destroyed, toxic dusts and vapors are formed which must not be inhaled. The dust can additionally cause irritations of the eyes, skin and respiratory tract. If a lens has been destroyed during operations, care is to be taken during removal and cleaning.

### 2.8.5 Protective measures for damaged optics

#### Protective measures in case of thermal decomposition and scratched or broken lenses

- For disposal use a protective mask or respiratory filter to prevent inhalation or ingestion of thorium.
- Wash hands thoroughly after contact with a scratched coating.

#### Protective measures in case of a broken lens

- Upon perception of an unpleasant odor, switch off the machine.
- Hold your breath.
- Leave the area of the machine.
- Before approaching the system again, wait for at least 30 min until the reaction has abated.
- Wear proper protective clothing (respiratory protection, protective goggles, protective suit, rubber or plastic gloves).
- Provide ventilation.
- When approaching the system again, pay attention to odors.
- Remove all lens fragments.
- Avoid raising or dispersing dust.



#### Disposal

The ZnSe dust and the lens are to be collected drily and disposed of with fragments, broom, shovel and protective clothing into hermetically sealable containers or plastics bags as hazardous waste.

**Do not dispose of optical components as domestic waste, and do not let them enter the sewer or water bodies.**

**Dispose of according to regulations and laws valid in the users' country.**

### 2.9 In case of emergency

#### In case of malfunction

- In case of unusual operating states, open the acrylic top lid to stop working process or respectively press the Emergency stop button, if available and switch off the laser device.
- When appropriate disconnect the machine from the mains.
- Inform laser safety officer and supervisor.
- Follow the Operating manual.
- Have repair work performed by Trotec Laser GmbH service technicians only.
- In case of fire: Use only CO<sub>2</sub> fire extinguisher to quench the fire, insofar as this is possible without endangering yourself.



#### Notice

After a deletion, Trotec Technical Support must be involved before the system is put back into operation.

#### In case of accident, First Aid

- If due to laser irradiation eye injury has occurred (upon exceedance of the maximum allowable irradiation rate), the accident victim must immediately be presented to an ophthalmologist.
- Assumption of eye injury is justified whenever laser irradiation has occurred and the maximum allowable irradiation rate may have been exceeded.
- First aider must pay attention to self-protection.
- Power off the device.
- Remove injured person from the danger zone and provide First Aid.
- Call emergency doctor!

**3 Technical Data**

→ The technical data sheet can be found in the appendix of this manual.

**3.1 Dimensions and weight**

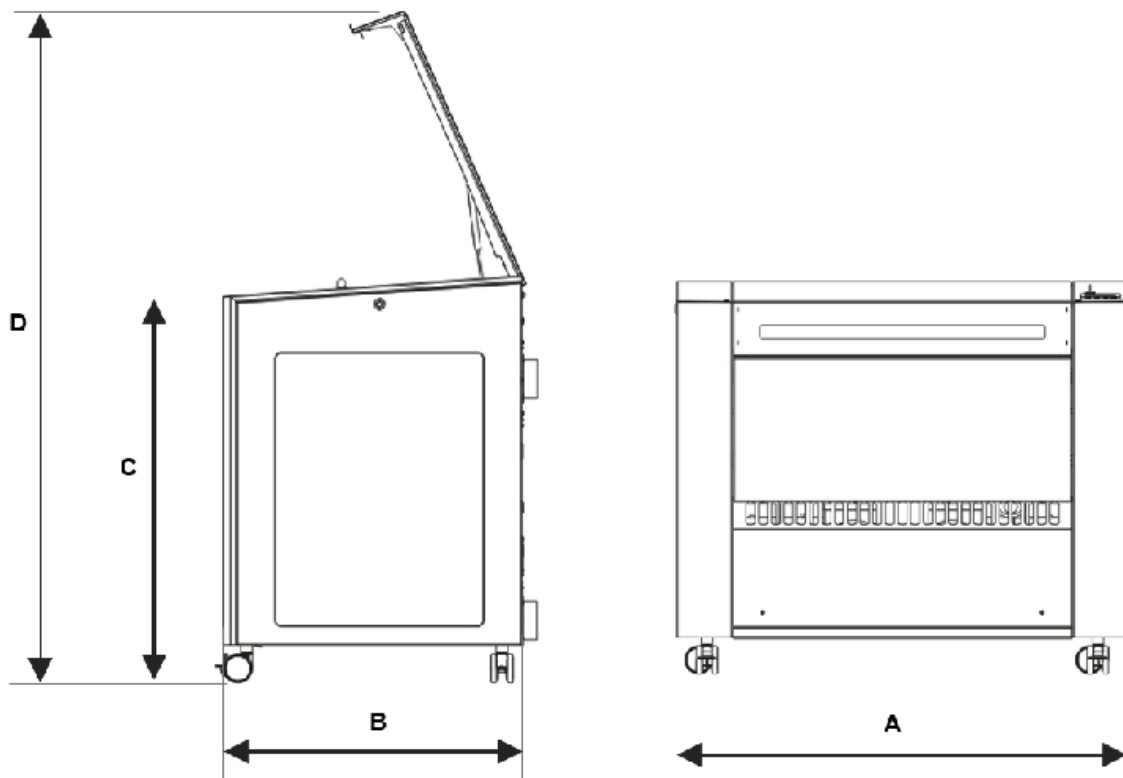

	Description	Dimension
A	Length	1221 mm (48 inch)
B	Width	830 mm (32.67 inch) / 790* mm (32.8 inch)*
C	Height, closed with base frame	1055 mm (41.55 inch)
D	Height, open	1750 mm (68.89 inch)

\* Without exhaust hose connectors on the back and with the top lid open.

Weight (depends on the machine type): 235 bis 250 kg (518 to 551 lbs)

**3.2 Electrical requirements of the machine**

Laser power	35–50 W (CO <sub>2</sub> ) 10-50 W (fiber) AC		55–80 W (CO <sub>2</sub> ) 10-50 W (fiber) AC		85–100 W (CO <sub>2</sub> ) 10-50 W (fiber) AC	105–120 W (CO <sub>2</sub> ) 10-50 W (fiber) AC
Voltage	230VAC	115VAC	230VAC	115VAC	230VAC	230VAC
Fuse	8AT	16AT	10AT	16AT	12AT	12AT
Power consumption	1200 W	1200 W	1400 W	1400 W	1900 W	1900 W

AC = air condition



**Caution**

Inadequate or inappropriate power sources can lead to machine damage and are not covered by any liability.

Verify that the electrical outlet is capable of providing the proper voltage, frequency and amperage required by the laser machine described in this manual.



**Caution**

Electrical noise, unstable power supply as well as voltage spikes in power supply can cause interference and possible damage to the electronics of the laser machine.



**Notice**

Use an individual circuit for the laser machine and the PC and an individual circuit for the exhaust system. Install your computer to the same circuit as the laser machine to prevent electromagnetic interactions.

Furthermore it is highly recommended that you use a overvoltage protection switch to protect your computer equipment.

If electrical power fluctuations, brownouts or power outages are a problem in your area, an electrical line stabilizer, UPS (Uninterruptible Power Supply) or backup generator are required. When installing any of these devices, ensure that they meet the electrical requirements of the laser machine.



### 3.3 Exhaust system requirements



#### Danger

##### Danger of emission of toxic gases, vapors or dust.

During laser operation, toxic aerosols may be produced.

- The laser system may be operated only with properly installed and operating exhaust system.
- Check with the material manufacturer for its toxic effect.



#### Caution

The laser may only be operated with properly installed and operating exhaust system. Damage to the system, caused by the use of not any exhaust system or improper extraction equipment, will not be covered by any liability.

The requirements for the exhaust system and recommended Trotec exhaust systems for standard applications depend on the working table installed in the machine.

#### Recommended exhaust systems for Speedy serie:

Exhaust system	Speedy 100	Speedy 300	Speedy 360	Speedy 400
<b>Atmos Nano</b>	✓ (only Speedy 100 fiber)	✓ (only Speedy 300 fiber)		
<b>Atmos Cube (Atmos Compact)</b>	✓ (without Speedy 100 flexx)			
<b>Atmos Mono</b>	✓	✓ (without vacuum table)	✓ (without table exhaust)	
<b>Atmos Mono Plus</b>	✓	✓ (without vacuum table)	✓ (without table exhaust)	
<b>Atmos Duo Plus</b>		✓	✓	✓
<b>Vent Set 300</b>	✓	✓ (without vacuum table)		
<b>Vent Set 400</b>	✓	✓	✓ (without vacuum table)	✓ (without vacuum table)
<b>Vent Set 500</b>		✓	✓	✓



## Notice

- Connection has to be carried out by our Technical Support.
- Observe instructions for operation and maintenance according to the operating manual of the exhaust system.

## Technical data of the corresponding exhaust systems:

Exhaust system	Hose connection $\varnothing$ [mm] (inside diameter)	Volume flow [m <sup>3</sup> /h]	Pressure [Pa]
<b>Atmos Nano</b>	45	200	8500 (230V)
<b>Atmos Cube (Atmos Compact)</b>	80	250	8500 (230V) 5800 (115V)
<b>Atmos Mono</b>	70	320	8500 (230V) 5800 (115V)
<b>Atmos Mono Plus</b>	70	320	8500 (230V) 5800 (115V)
<b>Atmos Duo Plus</b>	70	(2x) 320	8500 (230V)
<b>Vent Set 300</b>	80	max. 1000	max. 2550
<b>Vent Set 400</b>	100	max. 1000	max. 3800
<b>Vent Set 500</b>	100	max. 1200	max. 7000

## Requirements for the exhaust system:

Machine	Volume flow [m <sup>3</sup> /h]	Pressure [Pa]
<b>Speedy 100</b>	200	1000
<b>Speedy 300</b>	200 (without table exhaust)	1000 (without table exhaust)
	350 (with table exhaust)	1600 (with table exhaust)
<b>Speedy 360</b>	300 (without table exhaust)	2500 (without table exhaust)
	400 (with table exhaust)	4200 (with table exhaust)
<b>Speedy 400</b>	400	4200

The monitoring point for flow rate and pressure is at the exhaust port at the laser machine. Pressure loss by hoses / pipes or filter parts of the exhaust system has to be determined and additionally calculated when selecting a proper exhaust system.

A powerful exhaust system keeps the lifetime of optics and mechanical components, the cutting quality and the laser power interacting with the workpiece from being impaired by fumes and dust accumulating in the machine.



### Notice

The exhaust power available for the application will be reduced by e. g. bends, small hose diameters and long hoses.

#### You should therefore note the following:

- Avoid bends.
- Keep hose as short as possible.
- Use hose diameters as large as possible.

Applications generating large amounts of dust or fumes may require a stronger exhaust system. Use of separate exhaust systems for head and table exhaust may also be necessary.

In this case it is absolute necessary to consult your distributor.

## 3.4 Computer requirements

When using a more powerful computer, the graphics are generated and displayed faster, and the computing times and the times for data transfer to the laser are reduced.

#### The following recommendation represents the minimum requirements:

- Operating systems  
Windows Vista® 32/64-bit (with Service Pack 1 or later)  
Windows 7® 32/64-bit  
Windows 8® 32/64-bit  
Windows 8.1® 32/64-bit  
Windows 10® 32/64-bit
- Microsoft® .NET framework 3.5 or later
- Adobe® Reader 9.0 or later
- Local administrator privileges (for required software installations)
- 2 GHz processor or faster
- 2 GB RAM or greater (Windows Vista®, Windows 7 / 8 / 8.1 / 10)
- 80 GB hard driver or larger
- 1024 x 768 monitor resolution or greater
- True Color graphics card (24-bit color depth)
- 2 free USB interfaces
- DVD-ROM drive

3.5 Materials

		List of material								
Material EN	Material DE	Cutting			Engraving			Marking		
		CO <sub>2</sub>	Fiber	Flexx	CO <sub>2</sub>	Fiber	Flexx	CO <sub>2</sub>	Fiber	Flexx
<b>Metal</b>										
Aluminum	Aluminium					✓	✓		✓	✓
Aluminum, anodized	Aluminium, eloxiert					✓	✓	✓	✓	✓
Chromium	Chromium Verchromte Oberflächen					✓	✓		✓	✓
Precious metal	Edelmetalle					✓	✓		✓	✓
Metal foils up to 0.5mm (Aluminum, Brass, Copper, precious metal)	Metallfolien bis zu 0,5mm (Aluminium, Messing, Kupfer, Edelmetall)		✓	✓		✓	✓		✓	✓
Stainless steel	Edelstahl					✓	✓		✓	✓
Metal, painted	beschichtetes Metall (lackiert)				✓		✓			
Brass	Messing					✓	✓		✓	✓
Copper	Kupfer					✓	✓		✓	✓
Titanium	Titan					✓	✓		✓	✓

Plastic										
Acrylonitrile butadiene styrene (ABS)	Acrylnitril-ButadienStyrol-Copolymer (ABS)	✓		✓	✓		✓		✓	✓
Acrylic/PMMA, i.e. Plexiglas®	Acryl(PMMA), z.B. Plexiglas®	✓		✓	✓		✓		✓	✓
Rubber	Gummi (Stempelgummi)	✓		✓	✓		✓		✓	✓
Polyamide (PA)	Polyamid (PA)	✓		✓	✓		✓		✓	✓
Polybutylene terephthalate (PBT)	Polybutylenterephthalat (PBT)	✓		✓	✓		✓		✓	✓
Polycarbonate (PC)	Polycarbonat (PC)	✓		✓	✓		✓		✓	✓
Polyethylene (PE)	Polyethylen (PE)	✓		✓	✓		✓		✓	✓
Polyester (PES)	Polyester (PES)	✓		✓	✓		✓		✓	✓
Polyethylene terephthalate (PET)	Polyethylenterephthalat (PET)	✓		✓	✓		✓		✓	✓
Polyimide (PI)	Polyimid (PI)	✓		✓	✓		✓		✓	✓
Polyoxymethylene (POM) -i.e. Delrin®	Polyoxymethylen (POM) z.B. Delrin®	✓		✓	✓		✓		✓	✓
Polypropylene (PP)	Polypropylen (PP)	✓		✓	✓		✓		✓	✓
Polyphenylene sulfide (PPS)	Polyphenylensulfid (PPS)	✓		✓	✓		✓		✓	✓
Polystyrene (PS)	Polystyrol (PS)	✓		✓	✓		✓		✓	✓
Polyurethane (PUR)	Polyurethan (PUR)	✓		✓	✓		✓		✓	✓
Foam (PVC free)	Schaumstoff (PVC frei)	✓		✓	✓		✓		✓	✓

Miscellaneous										
Wood	Holz	✓		✓	✓		✓			
Mirror	Spiegel					✓	✓		✓	✓
Stone	Stein				✓		✓			
Paper (white)	Papier (weiß)	✓		✓	✓		✓	✓		✓
Paper (colored)	Papier (farbig)	✓		✓	✓		✓	✓	✓	✓
Food	Lebensmittel	✓	✓	✓	✓		✓	✓		✓
Leather	Leder	✓		✓	✓		✓	✓		✓
Fabric	Textilien	✓		✓	✓		✓			
Glass	Glas				✓		✓			
Ceramics	Keramik					✓	✓	✓	✓	✓
Cardboard	Karton	✓		✓	✓		✓	✓		✓
Cork	Kork	✓		✓	✓		✓	✓		✓
	Markierungsmittel (auf Metall oder Keramik/Glas) z.B. markSolid				✓		✓	✓		✓



## Warning

### Prohibited materials:

- Leather and artificial leather that contains chromium (VI)
- Carbon fibers (Carbon)
- Polyvinyl chloride (PVC)
- Polyvinyl butyral (PVB)
- Polytetrafluorethylene (PTFE, Teflon)
- Beryllium oxide
- Materials containing halogens (fluorine, chlorine, bromine, iodine and astatine), epoxy or phenolic resins.

### Take care when processing the following materials:

- Manganese
- Chromium
- Nickel
- Cobalt
- Copper
- Lead
- any material with the naming addition “flame-retarding” since it might contain bromine.



### **Warning**

#### **Serious injury or material damage.**

The use of prohibited or unreleased materials can cause serious injury or material damage and will not be covered under warranty.

Only use approved and released materials.



### **Notice**

Please contact our experienced application specialists or a sales partner near you, if:

- You are unsure about the processing of a material.
- You have additions for further materials for us or in your opinion a material was not listed.

We recommend performing a material processing test with the above mentioned material, using the appropriate configuration.

Trotec Laser GmbH assumes no responsibility for any consequences of laser processing in any application, especially with medical or pharmaceutical applications.

## 4 Machine overview

### 4.1 General overview

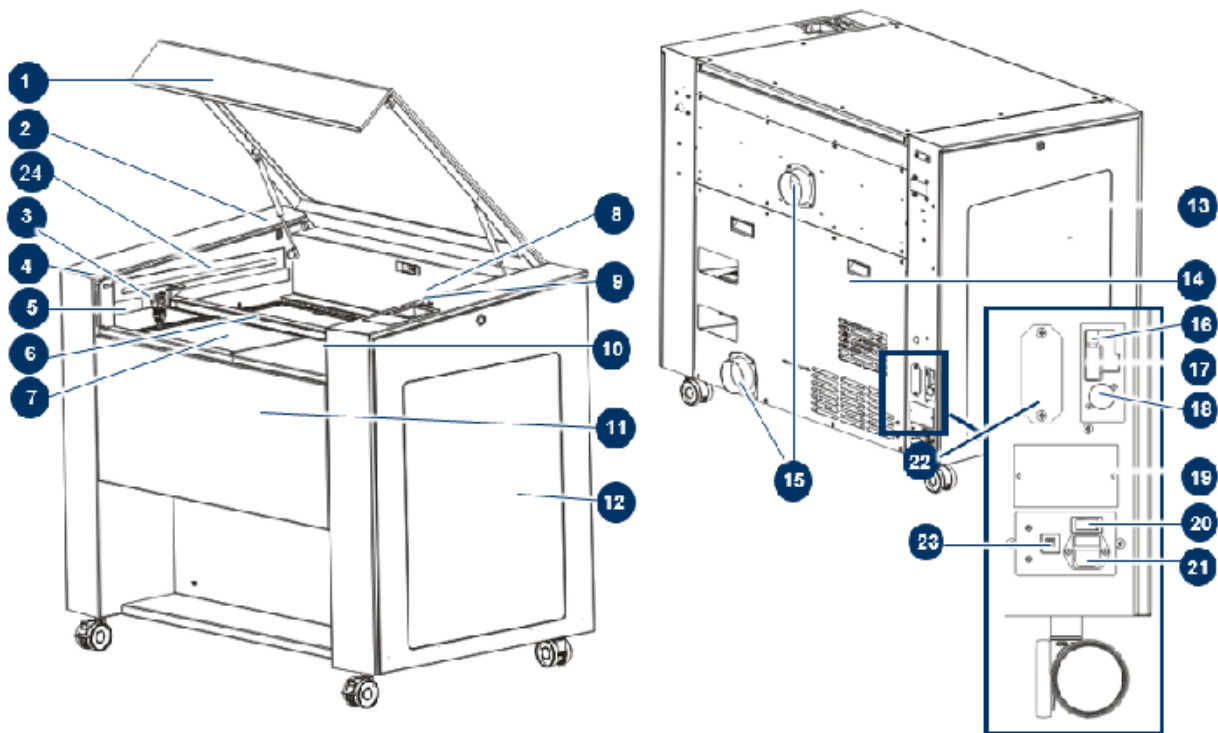

No	Description	No	Description
1	Acrylic top lid	13	Side panel left
2	Service plug connector	14	Cover for laser source and power supplies
3	Laser head	15	Connector for exhaust tube
4	Interlock safety switch	16	USB port for PC
5	Connector for rotary attachment	17	RS-232 port for PC
6	X-axis	18	Connectors for exhaust cable
7	Table	19	Type plate
8	Key switch	20	Main switch
9	Keypad	21	Mains connection
10	Interlock safety switch	22	Connector for JobControl@Vision
11	Front door	23	Fuse(s)
12	Side panel right	24	LED interior illumination



## 4.2 Front door

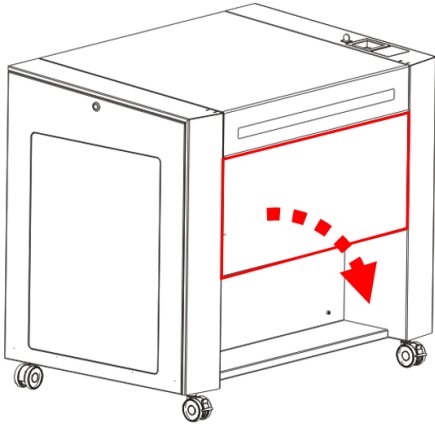

Loading and unloading of heavy and bulky parts or replacement of the table is very comfortable thanks to the front door that can be opened to up to 180°.



### Notice

The door is interlocked, therefore it must be closed before any laser operation is possible.

## 4.3 Tables (multifunctional table concept)

### Multifunctional base frame

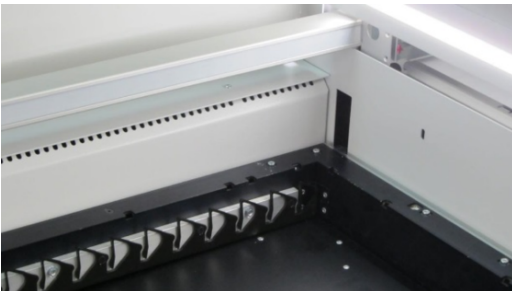

The multifunctional base frame is bolted to the mounting frame, which is attached to the Z-axis.



### Notice

All table variants rest on the base frame. With exception of the ferromagnetic engraving table which may also be placed directly on the mounting frame if there is no base frame present.

### Ferromagnetic engraving table



The ferromagnetic construction allows mounting thin materials such as paper, films or foils with magnets to ensure an even and flat surface. An even working area is essential for achieving optimal results for laser engraving and marking applications.

### Vacuum table



The vacuum table fixates various materials to the working table using vacuum. This ensures correct focusing over the entire surface, leading to better engraving results. In addition, it reduces the handling effort associated with mechanical mounting.

The vacuum table is the ideal table for thin and lightweight materials, such as paper, foils and films, that generally do not rest flatly on the surface.

### Aluminum slat cutting table



The cutting table with aluminum slats is ideal for cutting thicker materials (8 mm thickness and above) and for parts wider than 100 mm.

The slats can be arranged individually, consequently the table can be adjusted to each individual application.

### Acrylic slat cutting table



The cutting table with acrylic slats prevents reflection during cutting. This table is used in particular for cutting thicker materials (8 mm thickness and above) and for parts wider than 100 mm.

The slats can be arranged individually, consequently the table can be adjusted to each individual application.

### Aluminum cutting grid table

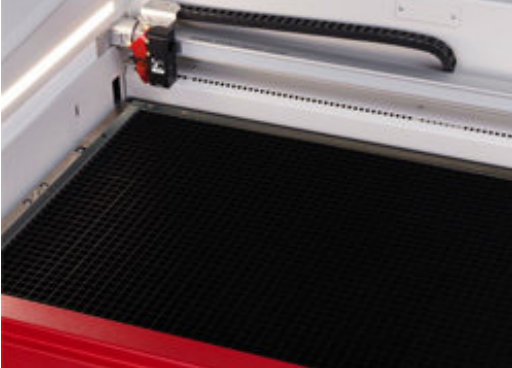

This robust cutting table offers excellent stability and is particularly suitable for cutting tasks with parts smaller than 100 mm, as these remain in a flat position after the cutting

### Acrylic cutting grid table

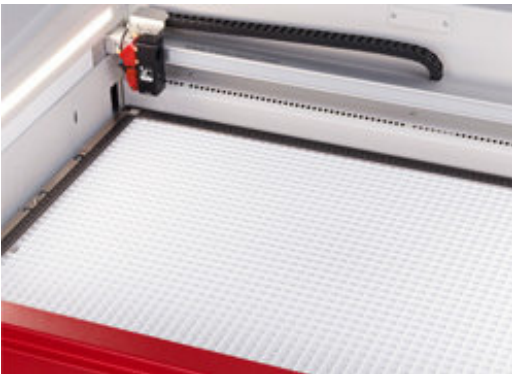

The special acrylic cutting grid table prevents reflection during cutting. It is therefore ideal for cutting acrylics, laminates or plastic films with parts smaller than 100 mm, as these remain in a flat position after the cutting.



#### Notice

The equipment of the machine may vary depending on the model.

### 4.3.1 Additional tabletops

#### Honeycomb tabletop

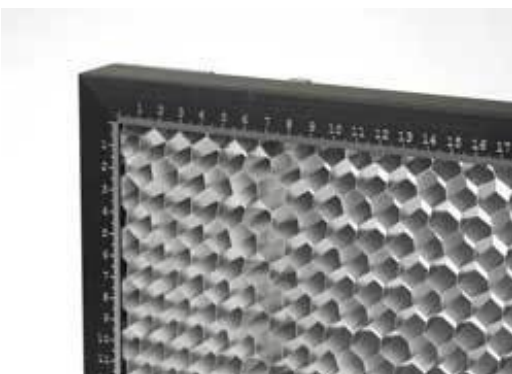

The honeycomb tabletop is especially suitable for applications that require minimal reflection and optimum flatness of the material, e.g. cutting of membrane keyboards.

The honeycomb tabletop is an additional option for the vacuum and ferromagnetic engraving tables.

#### Available in following sizes:

- 0.5 inch nominal comb size
- 0.25 inch nominal comb size

### 4.3.2 Table placement



1. Place a suitable table on the multifunctional base frame.



2. Fixate the table by pressing the push buttons.



#### Notice

All table variants rest on the base frame. However the ferromagnetic engraving table may also be placed directly on the mounting frame without the base frame.

#### Maximum material load is:

- For static loads up to 220 lbs (100 kg).
- For dynamic loads up to 66 lbs (30 kg).



#### Caution

#### Damage of the multifunctional base frame or impairment of the exhaust function.

When workpieces are processed directly in the multifunctional base frame without a table, the base frame be damaged, and impairment of the exhaust function is possible.

Process workpieces only on suitable tables.

4.4 Lens(es)

CO <sub>2</sub>		Fiber		Flexx	
	1.5" red Part number: 85973		3.2" green Part number: 1380		2.85" gold (standard) Part number: 9567
	2.0" black (standard) Part number: 85974		5.0" light blue Part number: 37781		
	2.0" CL brown Part number: 95909				
	2.5" silver Part number: 85975				
	4.0" blue Part number: 90026				



**Notice**

The equipment of the machine may vary depending on the model.

4.5 Nozzles



Ø 3

Short nozzle with small hole.



Ø 7

Short nozzle with big hole.

## 5 Transport

### 5.1 Safety notes



#### Warning

##### Risk of injury

There is risk of injury from falling parts during transport, loading and unloading of the machine.

- Follow the safety notes.

#### Observe the safety notes to avoid damage to the machine from improper handling during transport:

- Always move the machine with utmost care and attention.
- Transport the machine/machine components only in its original packaging.
- Take the machine's center of gravity into account when transporting it (minimize the risk of tipping over).
- Observe the packaging symbols (e.g. transport the machine only in upright position).
- Take measures to prevent the machine from slipping sideways, tipping or falling over.
- Transport the machine as carefully as possible in order to prevent damage.
- Avoid vibrations.
- When transporting the machine overseas, the device must be packaged airtight and protected against corrosion.
- When transporting outdoors, transport only in vehicles with roof or sufficient weather protection.
- Protect the machine against transportation damage using straps and inserts, and leave sufficient gaps to other transported items.
- Do not place any other loads or items on the machine or machine components.

### 5.2 Delivery state

Unless otherwise agreed, the machine is delivered in a wooden crate that contains the laser machine and additional accessories. Transport the machine only in its original packaging.



#### Caution

##### Risk of injury

There is risk of injury from falling parts during transport, loading and unloading of the machine.

- Follow the safety notes.

Observe the packaging symbols:



Keep dry!



Fragile, handle with care.



This way up!



Do not stack!

Note the shockwatch sign:

**TILTWATCH' XTR** - Überwachung  
- Monitored shipment  
- Transport contrôlé

**AUFRECHT TRANSPORTIEREN  
TENIR DEBOUT  
KEEP UPRIGHT**

**A T T E N T I O N**

**SHOCKWATCH' TILTWATCH' XTR**  
IF RED LIGHTS COME ON, SHIP OCCURRED

**VORSICHT**

**C A U T I O N**

1. TILTWATCH' XTR  
2. Wenn der Indikator rot ist  
3. TILTWATCH' XTR

**Transport Control International GmbH**  
Am Auck 4 · D-20112 Osterbek  
Tel: +49 (0) 40-714 679 0-0 Fax: +49 (0) 40-714 679 24  
E-Mail: info@transportcontrol.de Internet: www.transportcontrol.de

**SHOCKWATCH' - ÜBERWACHUNG  
SHOCKWATCH' - MONITORED SHIPMENT  
SHOCKWATCH' - TRANSPORT CONTRÔLÉ**

**SHOCKWATCH'**  
www.transportcontrol.de · 0 40 714 679 2007

**WARNING**

**HANDLE WITH CARE**  
READ INSTRUCTIONS BEFORE HANDLING  
IF RED LIGHTS COME ON THE BILL OF LADING  
AND INSPECT PRODUCT

**Wenn der Indikator rot ist:**

- Verweigern Sie nicht die Anordnungen.
- Überprüfen Sie roten Indikator auf dem Transporteur und überprüfen Sie die Ware sofort auf Schäden.
- Wenn Schäden aufgetreten sind, lassen Sie diese umgehend versichern und fordern Sie entsprechende Schutzmaßnahmen von Transporteur.

**If the indicator is red:**

- do not refuse delivery
- Make a note on delivery receipt of any inspection damage
- if damage is discovered, insure the packing and register the claim with appropriate insurance company immediately

**Si l'indicateur est rouge:**

- Ne pas refuser la livraison
- Indiquer sur le bon de livraison les dommages constatés et déclarer immédiatement à l'assureur
- Si des dommages sont constatés, assurer le colis et demander les mesures de protection appropriées au transporteur

**Transport Control International GmbH**  
Am Auck 4 · D-20112 Osterbek  
Tel: +49 (0) 40-714 679 0-0 Fax: +49 (0) 40-714 679 24  
E-Mail: info@transportcontrol.de Internet: www.transportcontrol.de



### 5.3 Temperature and humidity

#### Transport conditions

Transport temperature (ambiente temperature):	-10 °C to +40 °C
Relative humidity:	Maximum 70%, non-condensing

- Avoid high temperature fluctuations.

#### Storage conditions

Storage temperature (ambiente temperature):	+0 °C bis +30 °C
Relative humidity:	Maximum 60%, non-condensing

- Avoid high temperature fluctuations.

### 5.4 Required tools for unloading and transport

#### Required tools:

- Unloading - Forklift
- Transport - Pallet truck

### 5.5 Place of storage

- Keep the machine sealed in its packaging until it is assembled or installed.
- The storage location must be dry, free of dust, caustic materials, vapors and combustible materials.
- Store in a storage room or packaged with adequate weather protection.
- Avoid exposure of the machine to shocks or vibrations.
- Avoid extreme temperature fluctuations.
- Take particular care when packing away electronic components.
- When storing for a longer period, apply a coat of oil to all bare-metal machine parts.
- Regularly check the overall condition of all parts and of the packaging.

### 5.6 Transport inspection and reporting of defects

- Immediately after receipt inspect the delivery to ensure that it is complete and has not suffered any damage.
- If any transport damage is visible, do not accept the delivery, or accept it only with reservation.
- Record the scope of the damage on the transport documents or delivery note.
- For all defects that are not discovered upon delivery, be sure to report them as soon as they are detected, since damage claims must be filed within a certain period, as mandated by law.

## 5.7 Unpacking the machine

Only trained and authorized personnel are permitted to transport and unpack the machine. To avoid falling off of any wooden parts or tipping of the machine, be very careful when opening the transport case.



### Notice

Keep the original packaging case, in case of machine needs to be transported or relocate.

Dispose all waste according to the applicable waste disposal law.



### Caution

The lens unit should be unpacked only after installation of the machine. The lenses are high-quality optical components which must be kept clean in order to ensure optimum marking results. Never touch the lenses with bare fingers.

### Steps:

1. Position the transport case vertically on level ground (using a pallet truck or forklift).
2. Remove any vertical tightening straps.
3. First remove the top and afterwards the side plates of the transport case.
4. Slide out the two wooden rails in the form of ramps that are stored beneath the machine.
5. To secure the machine against moving, the wheels are locked using wooden blocks.  
In order to remove those blocks, put the two wooden rails together, push the upper part of the rails under one side of the machine and press down the rail in order to reach a levering effect.
6. Pull out the blocks.
7. Repeat this procedure on the opposite side as well.
8. Now you can pull out the blocks.

### 5.8 Relocation of the machine

#### Steps:

1. Switch off the machine.
2. Disconnect the power cable.
3. Remove the exhaust system.
4. Reposition the machine (e.g. with auxiliary equipment if necessary) and place it on a level, clean floor.
5. Adjust the machine.
6. Initial commissioning of the electrical system.
7. Carry out function test.



#### Caution

Transport the machine only in its original packaging. Ensure the wooden crates are properly secured otherwise the crates can slip, tip or fall over during transport.

Observe the corresponding safety norms and regulations from the chapters "Safety notes" and "Transport".

- When transporting over long distances, use transport boxes including transport securing.



#### Notice

If you would like to relocate the machine, contact our experienced Technical Support in your local area.

## 6 Setup and installation

### 6.1 For your safety



#### Notice

The setup has to be carried out by Technical Support.

### 6.2 Temperature and humidity

#### Ambiente conditions

Operating temperature (ambiente temperature):	+15 °C to +25 °C
Relative humidity:	45-65%, non-condensing

- If the system has been exposed to large temperature fluctuations, it must first be brought back to room temperature before commissioning.

#### Environmental conditions

- Provide sufficient illumination at the workplace.
- Ensure a dust-free environment (II° according to IEC60947-1).
- Shielding from EMC.
- Freedom of interfering electrical installations, hoses and pipe lines.
- Power supply free of fluctuations.

### 6.3 Space requirements

Ensure there is shielding or sufficient clearance to or from the wall and neighboring objects.

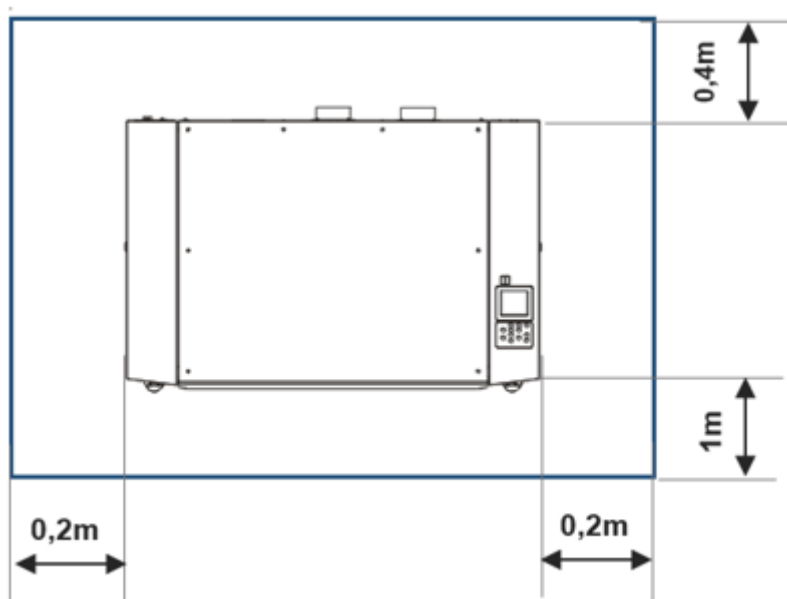

### 6.4 Setup

#### Observe the following steps:

1. Transport the machine to the installation location according to the specifications stated in the chapter "Transport".
2. Make sure all the packaging material has been removed.
3. Remove any transport protections.
4. Install the two exhaust connectors at the rear of the machine.  
They have been removed for safety reasons and for transport through doors.
5. The machine must stand upright.
6. Make sure the protective glass is intact.
7. Now connect the electrical components.
  - Mains connection
  - PC connection
  - Exhaust connection
8. Install the software and register your system during the installation process.

6.5 Connections



**Caution**

Install the connections exactly in the order described, otherwise electrostatic charging can damage your computer and/or the electronics of the laser system.

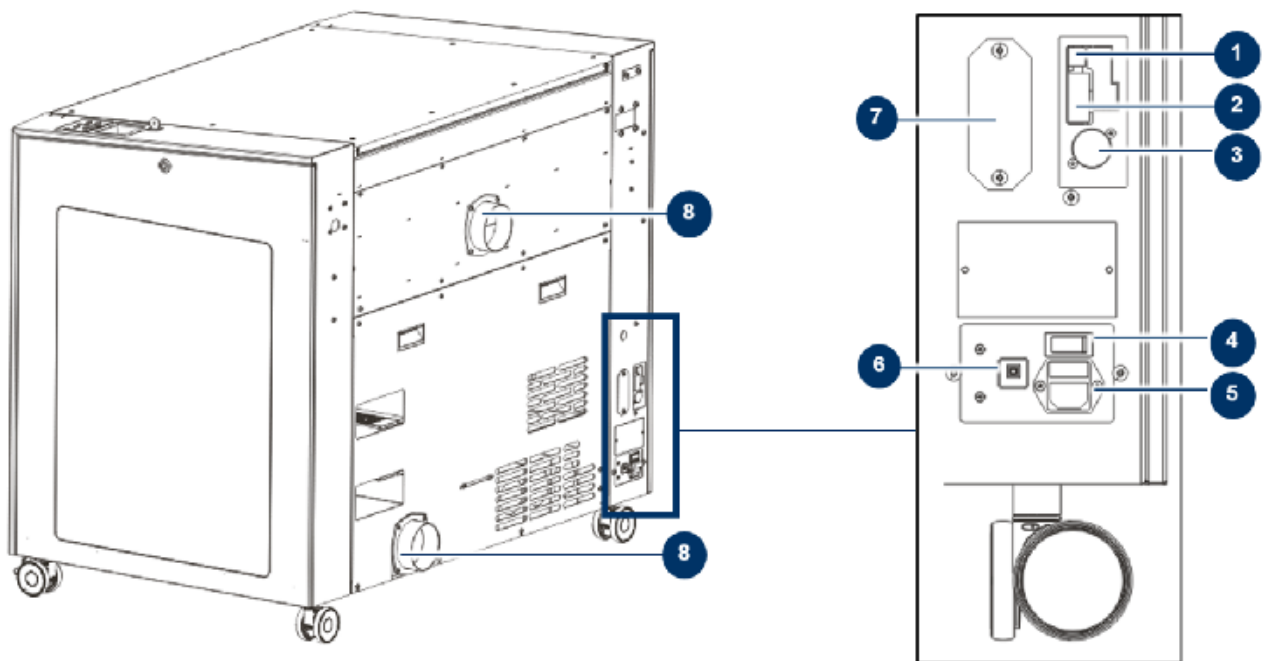

No	Description	No	Description
1	USB port for PC	5	Mains connection
2	RS-232 port for PC	6	Fuse
3	Connector for exhaust connection cable	7	JobControl® Vision connector
4	Main switch	8	Exhaust connection

### 6.5.1 Mains connection

- Connect the end of the mains connection cable to the main connection socket.



#### **Warning Current**

**Wrong voltage can cause damage to the machine.**

Do not operate the machine, if the mains voltage does not match the voltage required by the exhaust system, as this may cause damage to the machine.

Make sure that the mains voltage matches the voltage required by the exhaust system.



#### **Notice**

Depending on the laser type and region, the main fuses (6) are either covered or open next to the connector.

### 6.5.2 Connection the PC

1. Connect the laser to a free interface or USB port on your computer.
2. Connect the computer to the mains.
3. Switch on the computer.



## 6.6 Connection of additional components

### 6.6.1 Connecting an exhaust system from Trotec



#### Warning Current

**Wrong voltage can cause damage to the machine.**

Do not operate the machine, if the mains voltage does not match the voltage required by the exhaust system, as this may cause damage to the machine.

Make sure that the mains voltage matches the voltage required by the exhaust system.

#### Connecting:

1. When using an original Trotec exhaust system, also connect this, using the exhaust connection cable included, to the exhaust cable connection on the laser.
2. Plug the ends of the exhaust hose into the exhaust nozzle that is intended for this purpose on the exhaust system and on the laser. The position of the connector depends on the type of the exhaust system.
3. Plug in the mains cable of your exhaust system into the mains socket.

Follow the operation and maintenance instructions in the Manual of the exhaust system.

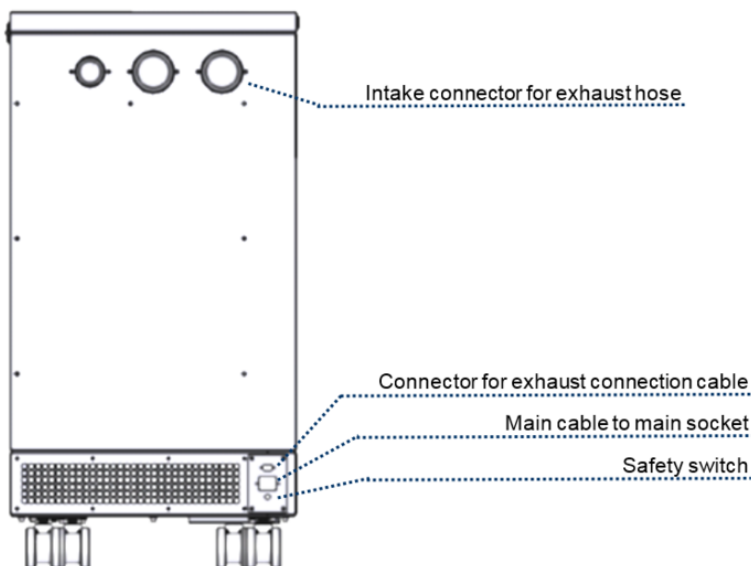

## 7 Operation



### Warning

#### Personal injury or damage to property due to improper operation.

Improper operation can lead to serious personal injury or damage to property.

- Work on the laser machine may only be carried out by authorized and instructed personnel familiar with the operation of the machine, observing all safety regulations.

### 7.1 Before commissioning

#### Check the following points before commissioning:

- Completeness and technically flawless condition of the machine and safety devices.
- Order and cleanliness at the workplace.
- Cleanliness of optical components (free of dust and dirt).
- Activated exhaust system.
- Complete electrical installation.
- Correct input voltage of the electrical installation.
- Environmental conditions according to technical specification.
- Compliance with all laser safety regulations and measures.
- Fulfill and compliance with all laser safety requirements.

If errors or functional deviations should occur during the inspection of the listed points, the machine is not considered to be safe to operate and must not (no longer) be put into operation until the cause has been clarified!

If you have any questions, contact our experienced Technical Support in your local area.

### 7.2 Software

For information on how to use the software, please read the accompanying software manual, which can be found on the supplied DVD.

### 7.3 Power On/Off



### Notice

In order not to restrict or obstruct the freedom of movement of the mechanics, no objects of any kind may be located in the machining area.

All safety protection covers have to be fully functional and closed.

### Maschine einschalten:



1. Switch on the main power supply using the main switch on the rear of the machine.
2. Turn the key switch to the right and hold it against the spring force.
3. As soon as the machine starts, release the key switch.
4. The referencing process starts.
5. A signal tone then sounds and the system is ready for operation.



### Notice

Additionally the ready-to-use state is indicated through the slow flashing of the green status LEDs.

### Maschine ausschalten:



1. Turn the key switch to the left.

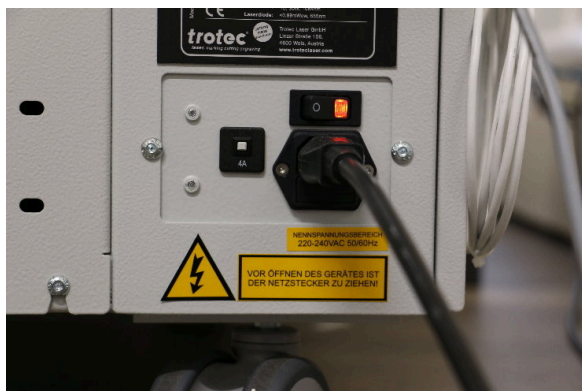

2. Use the main switch at the rear of the machine to turn off the main power.



### Notice

By switching off the mains, all processing data are lost.

## 7.4 Control panel

The control panel is the whole unit of the machine control.

The keypad is a part of the control panel.

### 7.4.1 Keypad

#### 1. Status indicator laser beam

LED On: The machine is processing data.

#### 2. Standby-button

LED On: Standby-mode

#### 3. Home-button

LED On: Temporary change of home position.

#### 4. Laser head control button X/Y

- travel distance in X-direction
- travel distance in Y-direction

#### 5. Working table control button Z

- Up-button
- Down-button
- automatic focusing (autofocus)

#### 10. Stop-button

#### 9. Start/Pause/Repeat-button

LED On: Pause-mode

#### 8. Status LEDs

Green, flashing slowly (0.5 Hz)	All covers are closed. Machine is ready.
Green, flashing fast (2 Hz)	Minimum one cover is open.
Blue + green, permanent	Data available. Pause-mode active.
Green, permanent	Job is running. Processing and receiving data.

#### 7. Shift-button

second operating level

#### 6. Exhaust-button

LED On: Exhaust active

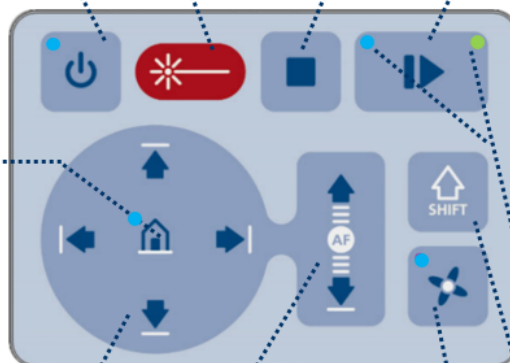

7.4.1.1 Description





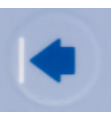

Image	Button	Description
	<b>Status indicator</b>	LED On: The machine is processing or receiving data.
	<b>Standby-button</b>	<p>LED On: Standby-mode</p> <ul style="list-style-type: none"> <li>• Press this button to switch to the Standby-mode.</li> <li>• Press the Standby-button while the working table is moving up or down (e.g. by focus automatically). The machine enters Standby-mode only after finishing the movement.</li> </ul>
	<b>Home-button</b>	<p>LED On: Temporary change of home position.</p> <ul style="list-style-type: none"> <li>• Press the Home-button for 3 seconds to temporarily define the position of the laser head as home position (Marker in JobControl®).</li> </ul> <p>To deactivate the temporary home position press the shortcut Shift-button + Home-button.</p>
   	<b>Laser head control button X/Y</b>	<ul style="list-style-type: none"> <li>• Press one of these buttons to manually move the laser head to the right, left, front or back (travel distance in X/Y-direction).</li> <li>• Press two of the for Laser head control buttons X/Y simultaneously in diagonal direction to move the laser in diagonal direction (X+/Y+, X+/Y-, X-/Y-, X-/Y+).</li> <li>• Press the Shift-button together with one any desired Laser head control button X/Y to move the laser head quickly to the corresponding end position.</li> </ul>

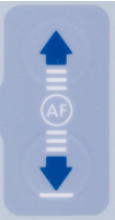

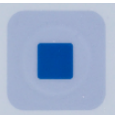

Image	Button	Description
	<b>Working table control button Z</b>	<ul style="list-style-type: none"> <li>Press one of these buttons to manually move the working table up or down (travel distance in Z-direction).</li> <li>Press the Shift-button together with the Up-button. The activation of the automatic focusing starts and the working table is moving automatically upwards.</li> <li>Press the Shift-button together with the Down-button. The working table is moving automatically downwards to the corresponding end position.</li> </ul> <p>By simultaneous pressing of the Up-button + Down-button, the activation of the automatic focusing starts and the working table is moving automatically upwards. Press any button in X-, Y-, or Z-direction to stop the automatically movement.</p> <p><b>Activation of the automatic focusing:</b> The laser beam gets automatically focused on the work piece (depends on the selected lens). When there is no work piece on the working area, the focus is on the table or rather on the tabletop.</p> <p><u>Sonar Technology™ (option):</u> Focusing on the material which is below the sensor.</p> <p> <b>Caution</b> If there is no material on the cutting table, it could lead to a collision of the laser head ("head crash").</p> <p><u>Light barrier:</u> Focusing on the material which is close to the sensor.</p> <p>→ For further information, see chapter "focusing" in this manual.</p>
	<b>Stop-button</b>	<ul style="list-style-type: none"> <li>Press this button to stop the current working process.</li> </ul>
	<b>Start/Pause/Repeat-button</b>	<p><b>Start:</b></p> <ul style="list-style-type: none"> <li>Press this button to start a job. The job has to be on the plate in JobControl®.</li> </ul> <p><b>Pause:</b></p> <ul style="list-style-type: none"> <li>Press this button to pause the job (LED On) which is currently being processed. Press this button again to continue the job (LED Off).</li> </ul> <p><b>Repeat:</b></p> <ul style="list-style-type: none"> <li>Press this button after a job was finished to repeat the actual job.</li> </ul>

Image	Button	Description
-------	--------	-------------



**Status LEDs**

**Meaning of the LEDs:**

LED	Description
Green, flashing slowly (0.5 Hz)	All covers are closed. Machine is ready.
Green, flashing fast (2 Hz)	Minimum one cover is open.
Blue + Green, permanent	Data available. Pause-mode active.
Green, permanent	Job is running. Processing and receiving data.



**Shift-button**

Second operating level for further operation. Press the Shift-button simultaneous with the buttons below to activate the following function:

Button	Description
Shift + Exhaust	Air assist On/Off.
Shift + Laser head X/Y	Laser head moves fast to corresponding end position (X- or Y-position).
Shift + Standby	Keypad locked/unlocked.
Shift + Working table Z, up	Working table is moving automatically upwards and the activation of the automatic focusing starts.
Shift + Working table Z, down	Working table is moving automatically downwards to the corresponding end position.
Shift + Home	Deactivates temporary home position.

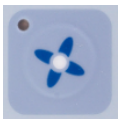

**Exhaust-button**

- Press this button to switch the exhaust On/Off.

LED On: Exhaust active.

LED Off: Exhaust deactivated.

After the laser process is completed, the exhaust switches off after some seconds ("Time to hold" in JobControl®) automatically or when you press the button.



7.4.1.2 Shortcuts













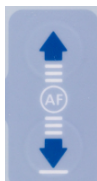

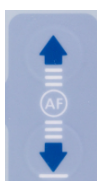
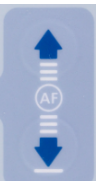











Image	Button	Description
 	Shift-button + Exhaust-button	Air assist On/Off.
 	Shift-button + Laser head control button X/Y	Laser head moves fast to corresponding end position (X- or Y-position).
 		
 		
 		
 	Shift-button + Standby-button	Keypad locked/unlocked.
 	Shift-button + Working table control button Z (Up-button)	Working table is moving automatically upwards and the activation of the automatic focusing starts.
 	Shift-button + Working table control button Z (Down-button)	Working table is moving automatically downwards to the corresponding end position.
	Working table control button Z (Up-button + Down-button)	Working table is moving automatically upwards and the activation of the automatic focusing starts. (See chapter "Description", "Working table control button Z").
 	Shift-button + Home-button	Deactivate temporary home position.

Image	Button	Description
 	Laser head control button X/Y	Laser head moves diagonal to the according direction.
 		
 		
 		

### Supplementary information:

Press the shortcut below to switch on/off the LED interior lighting.

Image	Button	Description
 	Shift-button+ Stop-button	LED interior lighting On/Off.

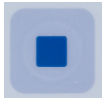
## 7.5 Lense placement

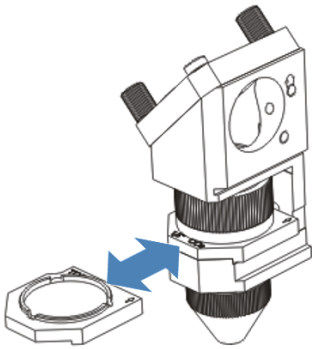

1. Loosen lens by turning the clamping ring inwards.
2. Remove lens.
3. Check the lens for damage.



4. If necessary, clean both sides of the lens with cleaning liquid and cleaning tissue.

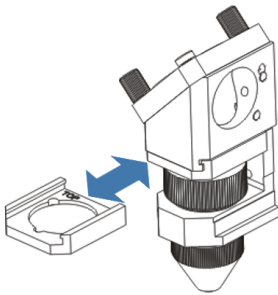

5. Insert the lens with the lettering facing up, either above or below the clamping ring depending on the lens type.
6. Fixate the lens with the clamping ring.

The following lenses must be inserted below the clamping ring:



1.5"



2.0"



### Notice

All other available lenses must be inserted above the clamping ring.

### 7.6 Focusing methods

Precise laser engraving depends on several factors. Apart from the right choice of lens, working tables and a corresponding exhaust system, correct focusing plays a key role.

The correct setting of the focus, which means the right distance between the laser head and the material to be engraved, is crucial for a perfect application result.



#### Notice

The machine described in these manuals is equipped either with light barrier focus or Sonar Technology™.

#### Manual focus mode

- Focus tool

#### Automatic focus modes

- Sonar Technology™ (automatic focusing with ultrasonic sensor)
- Software focus (JobControl®)
- Light bar focus



#### Caution

If workpieces with more than 66.14 lbs (30 kg) have been placed on the table, the table must not be moved up or down anymore as this might damage the mechanics of the machine.

It is mandatory to focus on the height of the material before loading material of 66.14 lbs (30 kg) and above.



#### Notice

Defects from head crashes (working head hits material or working table) are excluded from warranty.



#### Notice

The machine described in these manuals is equipped either with light barrier focus or Sonar Technology™.



#### Notice

The equipment of the machine may vary depending on the model.

7.6.1 Focus tool

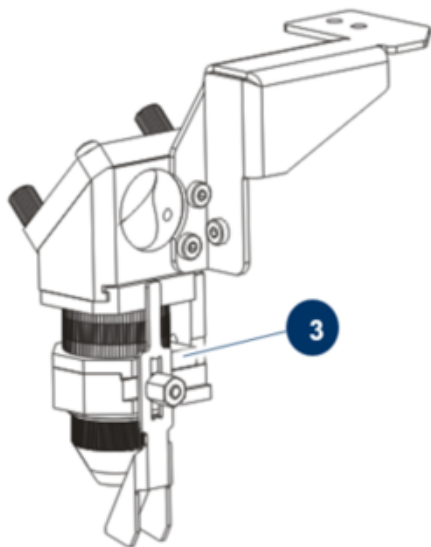
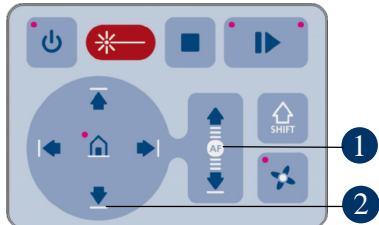

1. Move the processing head over the material to be engraved by means of the Laser head control button X/ Y (2) on the keypad.

2. Hang the focus tool (3) on the allocated space on the laser head so that the focus tool can move unhindered.
3. Move the X-axis downwards by pressing the Working table control button Z (1).
4. Before the focus tool reaches the workpiece, move the working table upwards very slowly and step by step by briefly tapping the working table control button Z (1) until the focus tool tilts to the side or falls off its position.

Now the lens is focused onto the surface of the material.

## 7.6.2 Sonar Technology™



### Caution

If the ultrasonic sensor is heavily soiled, the laser head may be damaged if it therefore hits the material or the worktable.

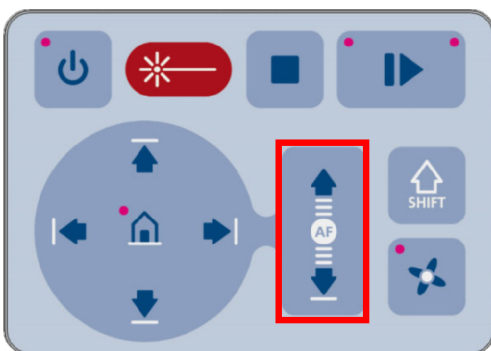

1. Make sure that the ultrasonic sensor is clean.
2. Select the lens type in the menu bar of JobControl®.
3. Press the two keys from the Working table control button Z simultaneously for the laser beam to get automatically focused on the workpiece.

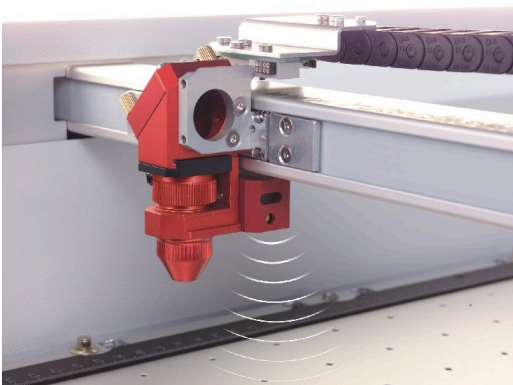

Focusing is then complete, and you can start the laser processing.



### Notice

This focusing mode is especially well-suited for all sound-releactive materials.

7.6.3 Software focus

The following values must be entered in JobControl®:

- Table type
- Lens type
- Material thickness (exact measurement)
- Material process type



**Caution**

The values entered must match the material, table and lens in the machine in order to avoid a head crash.

When using spacer the total material thickness is determined by the thickness of the spacer and the material.

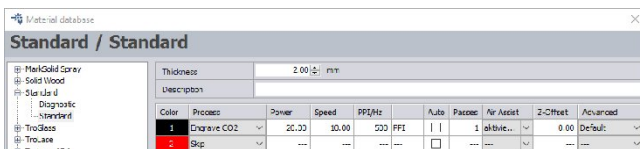
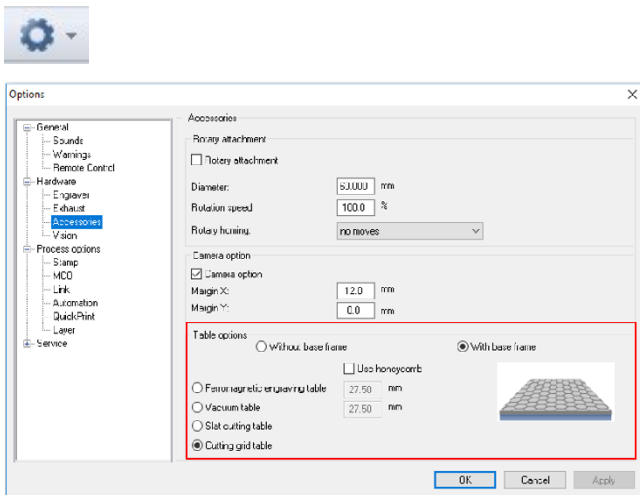

1. Click on the icon "Options" or go to Settings/ Options in the menu.
2. Select "Accessories".
3. When you are using a cutting table enter the table type and the thickness of the table.
4. Select the lens type in the menu bar.
5. Click on the icon "Material database" or go to Settings/Material database in the menu .
6. Enter the material thickness.
7. Enter the process type.
8. Click on the icon "Focus laser". The working table moves automatically to the correct position (moves in Z direction).

## 7.6.4 Light barrier focus

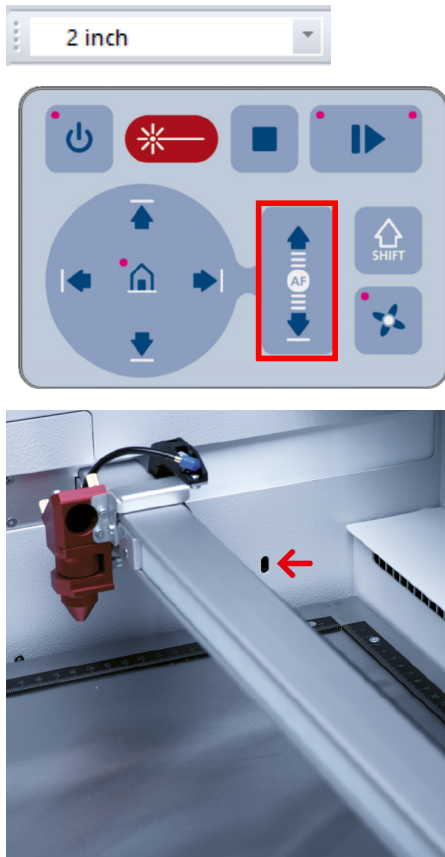

1. Select the lens type in the menu bar of JobControl®.
2. Make sure that the lens that is installed in the laser head is selected.
3. At the same time, press the Away key + Down key to adjust the height of the machining table so that it moves upwards.
4. Press the Up-button + Down-button simultaneously for the table to move up.
5. As soon as the previously loaded material passes the light barriers, the upward movement of the table stops, and the table moves to the correct focus position.

Focusing is then complete, and you can start the laser processing.



### Notice

The light barrier autofocus is ideal for flat opaque materials of unknown thickness.

This autofocus option will not work on transparent, rough or very thin material, which is thinner as the ruler itself.



## 7.7 Rotary attachment (option)

The Rotary attachment is used to engrave cylindrical workpieces. Upon selection of the option "Rotary attachment" in the JobControl® software and entering the diameter of the object to be engraved, the image size will automatically be automatically adjusted to the diameter of the workpiece to be processed.



### Caution

#### Damage to electronics.

Inserting or removing the Rotary attachment while the machine is turned on may irreparably damage the electronics.

Switch off the machine before inserting or removing the Rotary attachment.

#### Rotary attachment with cones:

Engraving of cylindrical objects with a diameter of up to 270 mm, a length of up to 760 mm and a maximum weight of 3 kg.

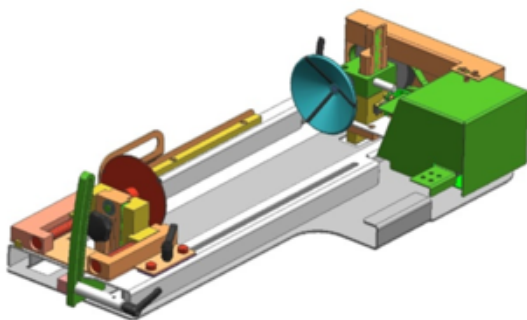

Figure 1: Rotary attachment with cones

#### Rotary attachment with rolls:

Engraving of cylindrical objects with a diameter of up to 180 mm, a length of up to 960 mm and a maximum weight of 10 kg.

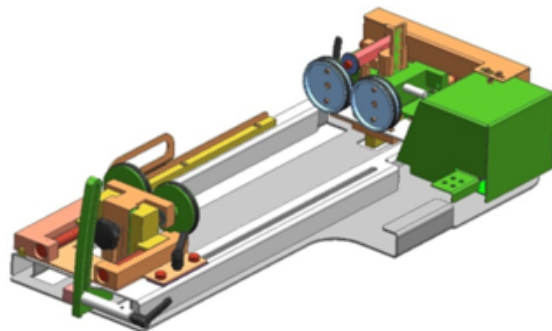

Figure 2: Rotary attachment with rolls

### 7.7.1 Installation and commissioning of the rotary attachment



1. A working table must be mounted and positioned at the lowest position. The laser machine must be switched off.
2. Place the rotary attachment onto the working table using the existing insertion handles.
3. Position the rotary attachment so that the brackets of the rotary snap to the ruler correctly.
4. Connect the connection cable of the rotary attachment to the connector on the left front side of the housing.

### 7.7.2 Mounting the work piece in the rotary attachment

1. Measure the diameter of the workpiece.
2. Adjust the height and angle of the system by loosening and fixing the levers.

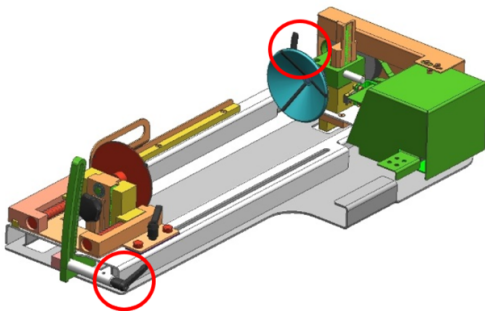

Figure 3: Levers for fixation of height and angle

3. Loosen the slider by using the lever in order to clamp the workpiece between the two cones or rolls.

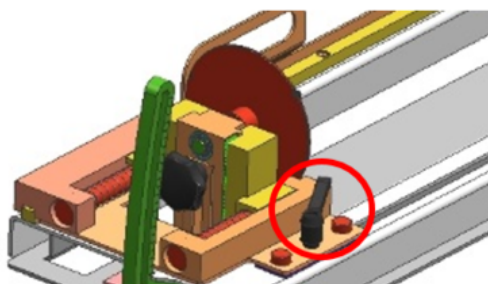

Figure 4: Schieberegler inklusive Hebel

4. Switch on the laser. The axis automatically moves over the middle of the rotary attachment.
5. Position the laser head over the workpiece at the position where you want to engrave.
6. Focus the object with the focus tool. The engraving area must be parallel to the X axis. If necessary, do this with the aid of the angle adjustment. Do not touch the lens holder.

### 7.7.3 Engraving process

1. Create a graphic with the help of the graphics software. Select the printer driver and rotary attachment, and enter the diameter of the workpiece.
2. Perform the settings for size and orientation in the JobControl® menu "Plate" > "Setup Plate" and choose - if necessary - the engraving material. You can determine the orientation of the graphic on the workpiece with the option "Job Orientation".
3. In the menu "Settings" > "Options" > "Accessories", select the option "Rotary Engraving" and enter the diameter of the object (see Fig. 6). If the diameter has already been entered in the printer driver, the size is automatically transferred into JobControl .

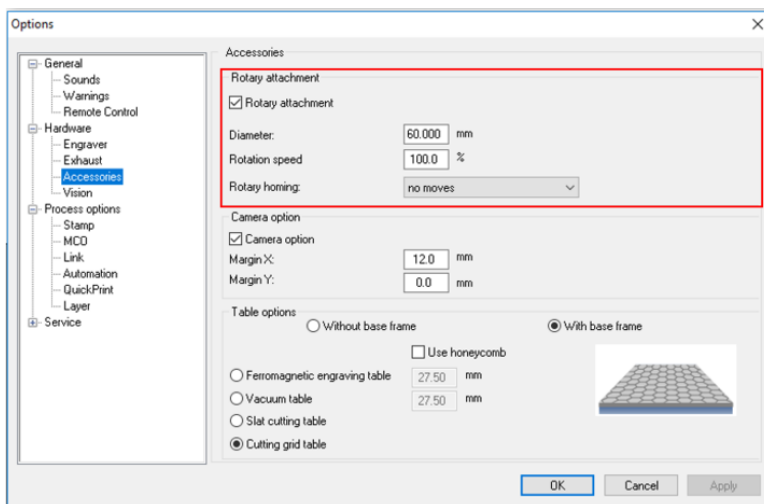



Figure 5: Einstellungen "Rundgravieren"

4. Double-click on the job in the waiting list to place it on the plate.
5. Position the laser head over the workpiece.
6. Start the engraving process. 



#### Notice

See the Software manual for additional functions.

When using the Rotary attachment, the autofocus is automatically deactivated.

## 8 Maintenance

### 8.1 Safety notes



#### **Danger**

**Improper maintenance can cause serious injury or damage.**

Maintenance may be carried out only by authorized, trained personnel who are familiar with how to operate the machine and in strict observance of all safety notes.



#### **Danger**

**Risk of fire or explosion.**

Improper handling of the machine may cause fire or explosion.

- For cleaning the machine, do not use explosive or flammable substances or cleaning agents.
- No flammable or explosive liquids may be stored in or near the machine.
- Always keep the system clean, and remove flammable parts from the working area or exhaust area.



#### **Warning Current**

**Danger of electrical shock.**

Work on electrical fittings may be carried out only by qualified personnel and in strict observance of the safety notes.

Before any maintenance work takes place, disconnect the machine from the mains voltage and make sure the system is de-energized.

## 8.2 Maintenance schedule

System Components	Daily	Weekly	Half-yearly	Yearly
Lens, mirror #4	✓✓			
Mirror #2 and mirror #3			✓✓	
Ultrasonic sensor (option)	✓✓			
Working table and rulers.	✓✓			
Vent slots of exhaust box. (inside the machine)	✓✓			
Entire working area. General cleaning.		✓		
Vent slots (backside of the machine)			✓✓	
Spindles				Clean and grease.
Cover of the laser source and housing.		✓		
Inside of the exhaust box.			✓✓	

✓✓ Check and clean whenever required.

✓ Clean whenever required.



### Notice

In order to ensure the maximum availability and lifetime of the system, we recommend that you regularly check the filter, ventilation and exhaust slots and keep the surrounding area clean. A visual inspection of the lenses is likewise recommended before switching on the system.

### 8.3 Cleaning

#### 8.3.1 Machine

1. Move the working table into a position in which it is easiest for you to clean the surface with a window cleaning agent and paper towels.
2. Switch off and disconnect the machine from the mains.
3. Open the transparent acrylic top lid and front panel.
4. Thoroughly remove all loose dirt particles and deposits in the interior of the machine (e.g. with a vacuum cleaner or broom).
5. Clean the air guide plate and vent slots of the exhaust box inside the machine using a dry or damp cloth or brush.
6. Clean the cover of the laser source and vent slots at the back of the machine using a dry or damp cloth.
7. Clean the transparent acrylic top lid using a dry or slightly damp cotton cloth. Do not use paper towels as they could scratch the acrylic.

### 8.3.2 Exhaust box

When cleaning the machine, also clean the outside and inside of the exhaust box as well.

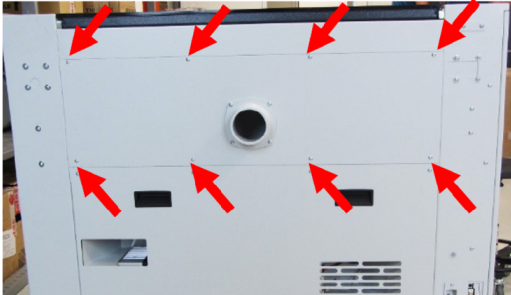

1. Remove the fixation screws of the exhaust box (8 screws).

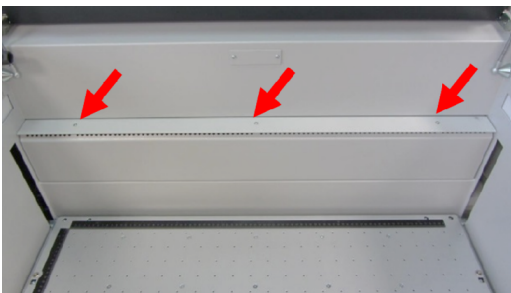

2. Unscrew and remove and clean the guide plate inside the machine (3 screws).



3. Remove the exhaust box from the machine and clean it.



4. To clean the inside of the box, remove the exhaust connector (4 screws).

The cleaning method depends on the material deposits (for example with the aid of a vacuum cleaner, wet cloth).

### 8.3.3 Optics in general

Trotec Laser GmbH recommends to use the cleaning set enclosed. Alternatively, use high-quality cotton swabs together with the provided cleaning liquid.



#### Notice

The following cleaning products are available as accessory parts:

- Lens cleaning cloth (Part number 69249)
- Lens cleaning liquid (Part number 69248)

### 8.3.4 Lens



#### Warning

##### Damage to optics.

Soiled optics absorb laser radiation and can thus be destroyed. Broken or damaged lenses as well as thermal decomposition of lenses release particles which cause serious damage to the health.

- The passive reflectors and optics in the area of the laser beam guidance should be cleaned regularly.
- Special care is required when handling, attaching and cleaning these elements.
- Do not exert non-uniform pressure.
- Do not use tools or hard objects to clean the surface.
- Never touch the optics with your bare fingers.
- Never use cleaning tissues twice.
- When lenses get broken, damaged or thermal decomposed follow the protective measures.
- Disposal according to regulations and laws valid in the user's country.
- Lenses with scratches or penetrations must not be used anymore.

#### Step1: Preparation

1. Blow away loose particles and dust by means of bellows or compressed air (according to ISO 8573:2010 class 1).
2. Get the cleaning liquid and cleaning tissues ready.
3. Move the table up and put a cloth under the lens holder (so that the lens will not be damaged if it falls out of holder by accident).
4. Loosen the lens by screwing the clamping ring inward.
5. Now remove the lens and check the surface.





## Step 2: Cleaning with cleaning liquid and cleaning tissues

1. Remove the lens and rinse it with cleaning liquid to wash away coarse soiling.
2. Put some cleaning liquid onto the lens and leave the liquid for 1 minute to take effect.
3. Soak a cleaning tissue with cleaning liquid and carefully wipe off the surface.
4. Now carefully insert the lens with the lens holder into the laser head and fixate the clamping ring.



### Notice

Trotec Laser GmbH recommends to use the following cleaning products, which are available as accessory parts:

Lens cleaning cloth (part number 69249) and lens cleaning liquid (part number 69248).

## 8.3.5 Mirror

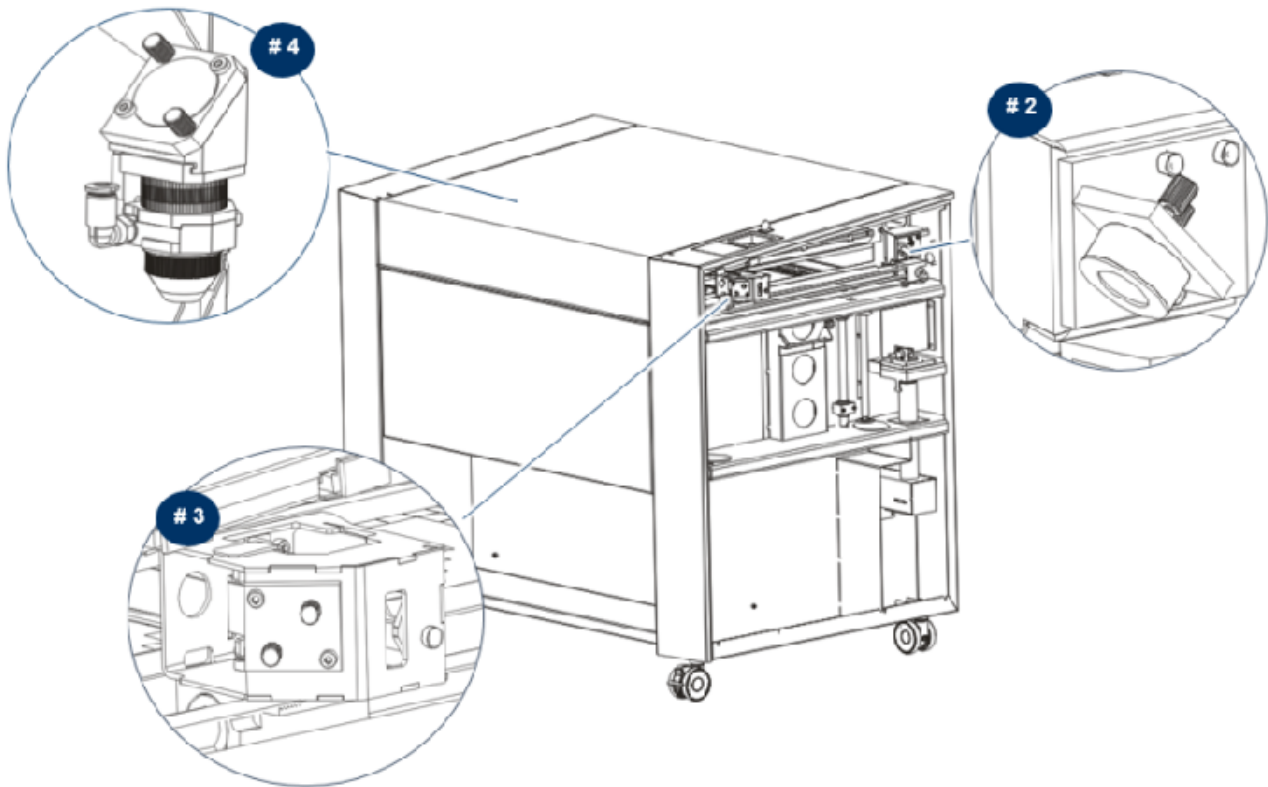

### Caution

Make sure that you do not touch the mirror with your fingers, since this would greatly reduce the service life of the mirror.

Do not touch the mirror with your fingers or with tools, and never use a cleaning tissue twice, as the surface could easily be scratched.

### Reinigung der Spiegel #2 und #3

1. For cleaning of mirrors #2 and #3, you must first remove the right maintenance panel.
2. Do not remove the mirror #2. It must remain in the machine for cleaning.
3. The mirror #3 is attached by means of two Allen screws (1), which are located on the mirror holder. Open the screws and remove the lens holder together with the mirror.

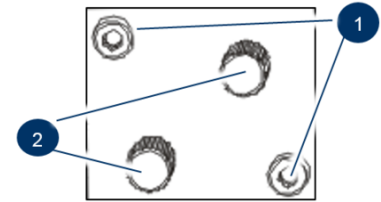

Figure 6: SpiMirror #3

#### Do not touch the milled screws (2) while doing this!

4. Flush the mirror with cleaning liquid to wash away coarse soiling.
5. Put some cleaning liquid onto the mirror and leave the liquid for 1 minute to take effect.
6. Soak a cleaning tissue with cleaning liquid and carefully wipe off the surface.
7. Now carefully put back the mirror and fixate it with the two Allen screws.

### Reinigung des Spiegels #4

1. While holding the mirror, loosen the two knurled screws (1) and lift the mirror from the mirror holder.



#### Caution

Make sure that the mirror does not grind over the mirror holder, as it can be scratched very easily.

2. Flush the mirror with cleaning liquid to wash away coarse soiling.
3. Put some cleaning liquid onto the mirror and leave the liquid for 1 minute to take effect.
4. Soak a cleaning tissue with cleaning liquid and carefully wipe off the surface.
5. Now carefully re-insert the mirror and fixate it with the two knurled screws.

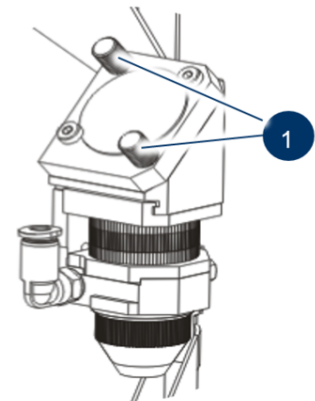

Figure 7: Mirror #4

### 8.3.6 Ultrasonic sensor (Option Sonar Technology™)

The sensor can be cleaned either with a brush, or be wiped drily, with moisture or with mild detergents and a microfiber or anti-statics cloth. In case of stronger soiling, isopropyl or ethanol solution can be used.

Avoid long application time and long-term usage.

## 9 Troubleshooting

This chapter should enable the maintenance personnel to identify and resolve operational faults based on error messages and symptoms.



### Warning

#### Risk of fire from incorrect parameter settings.

Laser operation with incorrect parameter settings such as power settings, speed or frequency can result in flame formation.

- Laser operation permitted only under supervision.



### Caution

System failures that cannot be remedied can cause damage to the machine.

- Disconnect the machine from the mains and contact your local Technical Support.

### 9.1 Error, cause and remedy

Problem	Possible cause	Remedy
<b>Too low engraving depth.</b>	<ul style="list-style-type: none"> <li>• Imprecise focusing.</li> <li>• Dirty optics.</li> </ul>	<ul style="list-style-type: none"> <li>• Check focus.</li> <li>• Clean optics.</li> </ul>
<b>Blurred edges.</b>	<ul style="list-style-type: none"> <li>• Imprecise focusing.</li> </ul>	<ul style="list-style-type: none"> <li>• Check focus.</li> </ul>
<b>Missing cut lines.</b>	<ul style="list-style-type: none"> <li>• Zero passes in material database.</li> <li>• Line thickness in CorelDraw too big.</li> <li>• Color was skipped in JobControl®.</li> </ul>	<ul style="list-style-type: none"> <li>• Increase the amount of passes in the JobControl® material database.</li> <li>• Reduce line thickness to the smallest possible value.</li> <li>• Set color to cutting in the JobControl® database.</li> </ul>
<b>Waviness of the lines.</b>	<ul style="list-style-type: none"> <li>• Lens is loose.</li> </ul>	<ul style="list-style-type: none"> <li>• Check lens and lens holder.</li> </ul>
<b>No visible marking result.</b>	<ul style="list-style-type: none"> <li>• Too low laser power.</li> <li>• Too high speed.</li> <li>• Not focused.</li> <li>• Wrong focus tool.</li> </ul>	<ul style="list-style-type: none"> <li>• Increase power setting.</li> <li>• Reduce speed.</li> <li>• Check focus.</li> <li>• Change focus tool.</li> <li>• When using autofocus, check the settings within the software (lens, material thickness, table).</li> </ul>

Problem	Possible cause	Remedy
<b>Fine details on stamps are engraved too thinly.</b>	<ul style="list-style-type: none"> <li>• Too steep shoulders.</li> </ul>	<ul style="list-style-type: none"> <li>• Choose other shoulder or edit (flat/medium/steep): Options/ Process Options/Stamp.</li> </ul>
<b>The size to be engraved or cut does not match the size in CorelDraw.</b>	<ul style="list-style-type: none"> <li>• Raster correction ON in JobControl®.</li> <li>• Wrong size settings in the printer driver.</li> <li>• Wrong image position is selected in the layout tab (printing).</li> <li>• Wrong machine is selected in the JobControl®.</li> </ul>	<ul style="list-style-type: none"> <li>• Switch off raster correction in JobControl® (settings/ advanced options/laser tab).</li> <li>• Use the same size as in CorelDraw.</li> <li>• Switch the layout settings to: as in document.</li> <li>• Select the proper machine in JobControl®.</li> </ul>
<b>Corners and angles are not cut or marked.</b>	<ul style="list-style-type: none"> <li>• Power too low.</li> </ul>	<ul style="list-style-type: none"> <li>• Increase the correction in JobControl® (Settings / Material Templates Setup - Correction).</li> </ul>
<b>No referencing after comissioning.</b>	<ul style="list-style-type: none"> <li>• Top, front or side door not closed.</li> </ul>	<ul style="list-style-type: none"> <li>• Close doors.</li> </ul>
<b>No response upon switching on of the system.</b>	<ul style="list-style-type: none"> <li>• Fuse blown.</li> <li>• No electric power at power outlet.</li> </ul>	<ul style="list-style-type: none"> <li>• Check fuses.</li> <li>• Check power outlet.</li> </ul>
<b>No communication with machine.</b>	<ul style="list-style-type: none"> <li>• Invalid COM port selection.</li> <li>• Communication cable defect.</li> <li>• COM: port is in use by another program.</li> </ul>	<ul style="list-style-type: none"> <li>• Change selection.</li> <li>• Check cable.</li> <li>• Close this program, or change the COM port.</li> </ul>
<b>Connection to machine frequently interrupted.</b>	<ul style="list-style-type: none"> <li>• Electromagnetic emissions.</li> </ul>	<ul style="list-style-type: none"> <li>• Make sure that machine and computer are connected to the same electric circuit; the original cable lengths should not be exceeded.</li> </ul>
<b>Offsets between engraving jobs and cut lines.</b>	<ul style="list-style-type: none"> <li>• Speed too high.</li> </ul>	<ul style="list-style-type: none"> <li>• Reduce speed.</li> </ul>
<b>Other faults.</b>		<ul style="list-style-type: none"> <li>• Contact Technical Support.</li> </ul>

## 9.1.1 How to create a service file

1. Start the software JobControl®.
2. Position the job on the plate.
3. Run the job.
4. Go to "Settings" and select "Create Service file".

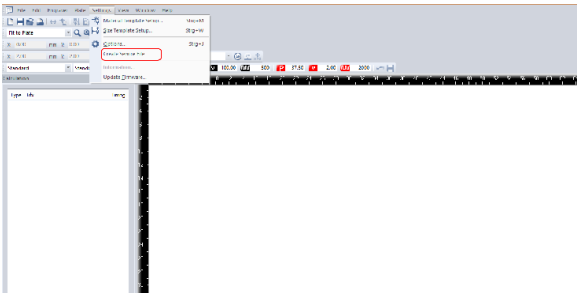

5. The window "Save Service File to" shows up. Select a directory to save the file into and click on "Save".
6. The window "Add Layout File" appears. Select the layout file that was sent to JobControl® and possibly caused a failure (e.g.: a CorelDraw file, Photoshop file, AutoCAD file,...).
7. Click on "Open".

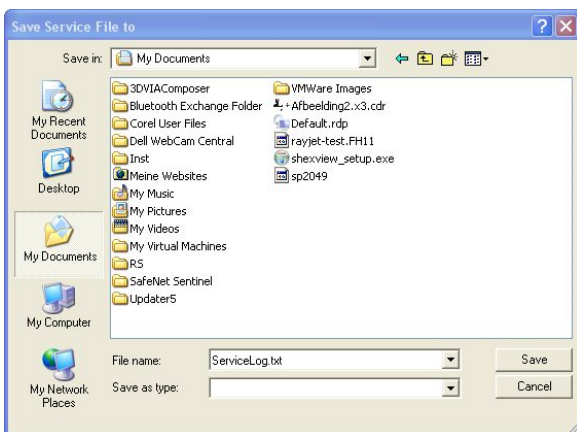

8. The location to which the successfully created service file was saved appears on the screen.

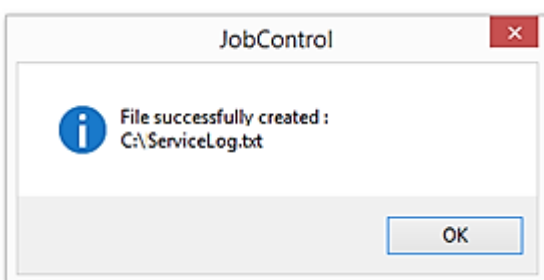

9. Send the service file "SeviceLog.txt", a screenshot of the error message and a detailed description to your sales representative or to [techsupport@troteclaser.com](mailto:techsupport@troteclaser.com).

## 10 Contact details

### Technical Support

In case of questions, contact our experienced Technical Support in your local area.

For global service contact numbers and further information please see our website, section "Support":  
**[www.troteclaser.com](http://www.troteclaser.com)**

When calling, please make sure that the machine is in your immediate vicinity, and that you have the following information ready (see response form):

- At which working process did the problem occur?
- What you have done so far to correct the problem.
- Serial no (see type plate).
- Error code.

### Local Offices / Sales

Our store locator and detailed information on our offices in your area can be found on our website in section "Contact", "Local Office": **[www.troteclaser.com](http://www.troteclaser.com)**

### Technical Documentation

For feedback or to suggest changes to this manual, contact:

Technical documentation: +43 (0) 7242 239 - 7000

E-Mail: **[technical.documentation@troteclaser.com](mailto:technical.documentation@troteclaser.com)**

### 11 Disassembly



#### **Warning**

##### **Danger of injury when disassembling the machine.**

There is danger of injury when disassembling the machine.

Always wear suitable protective clothing (e.g. safety goggles, safety shoes, safety gloves).



#### **Warning Current**

##### **Electric current.**

The machine must be disconnected from the main power supply.



#### **Notice**

- Always use suitable tools to disassemble the machine.
- Mind the springs.
- Follow chapter "Disposal".

#### **Process:**

1. Remove all workpieces from the system.
2. Turn the key switch to switch off the machine.
3. Switch off the main switch at the back of the machine.
4. Remove the exhaust system.
5. Disconnect all cables at the back of the machine.



12 Disposal



**Disposal**

**Do not dispose of the machine with domestic waste!**

Electronic devices have to be disposed of according to the regional directives on electronic and electric waste disposal.

In case of further questions, please ask your supplier.

Use suitable tools if you have to disassemble the machine. All parts need to be sorted into the individual material types and be disposed of according to the regional directives on electronic and electric waste disposal.

**13 Appendix**

- ✓ **Technical Data**
- ✓ **Conformity Declaration**
- ✓ **Acceptance report**
- ✓ **Response form**
- ✓ **Training verification form**



## Speedy 360 – Technical Specifications

### • Mechanics

Working area	32 × 20 in (813 × 508 mm)
Loading area	35 × 23.6 in (890 × 600 mm)
Max. height of work piece	1.5 ", 2.0 ": 8.2 in (210 mm) incl. working table / 11 in (280 mm) without working table 2.0 " clearance lens, 2.5 ": 7.7 in (197,5 mm) 4.0 ": 6.2 in (159 mm)
Working tables	Multifunctional table concept including aluminum cutting grid table, Rulers in inch or mm Electronic, programmable Z-axis with servo motor
Speed of motion system	139 in/sec (355 cm/sec.)
Acceleration	5g
Motor	Brushless DC servomotor
Encoder	Increment measuring system
Lenses	Standard: 2.0 " Optional: 1.5", 2.0 " clearance lens – 0.5 in (12,5 mm) more distance from material than standard lenses, 2.5 ", 4.0 "
Addressable accuracy	5 µm
Repeat accuracy	<± 0.0006 in (0,015 mm)
Accuracy to size of parts	Depending on material and process
Max. material load	Static: up to 220 lbs. (100kg) / Dynamic: up to 66 lbs. (30 kg)
Exhaust	Surface exhaust via rear of the engraving cabinet, table exhaust with vacuum and cutting table
Standard features	Sonar Technology™, ergonomic access to working area, coaxial air assist incl. integrated pump, InPack Technology™, harsh environment protection kit, multifunctional table concept incl. aluminum cutting grid table (black), laser pointer (655 nm, <0,99mWcw), 2.0 " lens, nozzles (Ø3 mm und Ø7 mm), LED light, housing with lockable casters, incl. water-chiller (if requested), 2 years warranty or 3 years extended warranty in combination with TroCare USB connection, JobControl® Expert Software, UniDrive, iOS App
Optional	Rotary attachment, gas-kit light, temperature sensor incl. emergency stop button, ferromagnetic engraving table, vacuum table, acrylic cutting grid table (white), aluminum slat cutting table, acrylic slat cutting table, honeycomb cutting table top with 0.5 in (12.7 mm) or 0.25 in (6,4 mm) nominal comb size Job Control® Vision, UniDrive, MCO option for pad cutting

### • Options

Rotary attachment	Cone, roll or combined version, tiltable Max. workpiece length cones: 21.6 in (550 mm) Max. workpiece length rolls: Ø ≥ 2.2 in (58 mm) = 26.7 in (679 mm), Ø ≤ 2.2
-------------------	--





	in (58 mm) = 29.3 in (745 mm) Max. workpiece diameter cones: 8.1 in (207 mm), depending on inserted lens Max. workpiece diameter rolls: 3.7 in (96 mm), depending on inserted lens
JobControl <sup>®</sup> Vision	Registration marks detection and compensation system Max. working area without camera: 32 × 20 in (813 × 508 mm) Max. working area with camera: 31.5 × 20 in (801 × 508 mm)
Vacuum table	Vacuum effect for fixation of thin or wavy materials
Honeycomb cutting tabletop	Perfect in combination with vacuum table; 0.5 in (12.7 mm) or 0.25 (6,4 mm) nominal comb size
Ferromagnetic engraving table	Allows to mount thin materials such as paper, films or foils with magnets to ensure an even and flat surface. An even working is essential for achieving optimal results for laser engraving and marking applications
Acrylic cutting grid table	For reflection free cutting of tasks with parts smaller than 4 in (100 mm)
Aluminum slat cutting table	Particularly suitable for cutting tasks of thicker materials and parts bigger than 4 in (100 mm); removable aluminum slats
Acrylic slat cutting table	For reflection-free cutting of thicker materials and parts bigger than 4 in (100 mm); removable acrylic slats
Gas-Kit light (for compressed air connection)	For control of compressed air (free of mechanical dust, water and oil) max. flow rate 150 l/min (40 gpm) with max. 10 bar (145 psi); max. limit 4 bar on working head, connection on the machine with external hose diameter of 0.23 in (6mm)
UniDrive	Increased flexibility by the use of different operating systems e.g. MAC and multiple design stations, workflow optimization
TroCAM	CAD / CAM software for perfect cutting results; including nesting-function, lead-in/lead-out, tool paths
MCO	Multi-Color Option for stamp pad cutting
<b>• Control System</b>	
Software	JobControl X Expert
Laser Power	Adjustable 0 – 100%
Interface hardware	USB
Interface software	ASCII, HPGL, JobControl
<b>• Laser Equipment CO<sub>2</sub></b>	
Laser tube	Sealed-off CO <sub>2</sub> laser, maintenance-free Laser power: 40 - 120 W, air cooled
Wavelength	10.6 μm





• **Dimensions**

Width/depth/height	48 × 32.8 (30.7*) × 41.5 in (1221 × 830 (790*) × 1055 mm) * without exhaust hose connection on the back of the machine and open top lid
Weight	Approx. 518 – 551 lbs. (approx. 235 - 250kg) – depending on laser power
Ambient conditions	Mandatory ambient temperature +15° C to +25° C or 59° F to 77° F Humidity 40% to max.. 70%, not condensing Dust-free environment (2nd degree according to IEC 60947-1)

• **Laser Safety**

Laser class	CDRH laser safety; CE tested Laser class 2
Interlock	Duplicate interlock safety system
Loading lid	Front-side loading lid

• **Extraction System**

Minimum volume required (without piping/tubing)	300 m <sup>3</sup> /h @ 1.700 Pa (without multifunctional table concept) 350 m <sup>3</sup> /h @ 3.500 Pa (with multifunctional table concept) Two connections DN 2.95 in (75 mm)
Required	Without multifunctional table concept: Atmos Mono/Mono Plus, Vent 3000 (or equivalent systems; for surface extraction) With multifunctional table concept: : Atmos Duo Plus, Vent HP (or equivalent systems; for surface and table extraction)

• **Electrical Equipment**

Power consumption	Approx. 1.2 to 1.9 kW (depending on laser power)
-------------------	--



## **EC–Declaration of Conformity**

(Machine directive 2006/42/EG, appendix II A)

### **Manufacturer:**

TROTEC Laser GmbH  
Linzer Straße 156,  
A-4600 Wels

### **Authorized person for the compilation of technical documentation:**

Gerhard KREMPL, TROTEC Laser GmbH, Linzer Straße 156, A-4600 Wels

We hereby certify that

SPEEDY 360  
Modell N° 8030 Speedy 360

in its conception, construction and form put by us into circulation is in accordance with all the relevant essential health and safety requirements of the EC machinery directive 2006/42/EEC.

### **Further valid guidelines/regulations for the product:**

2014/35/EG Low Voltage Directive  
2014/30/EG EMC Guideline

### **Applied harmonized standards:**

- EN ISO12100:2011-03 Machine Safety
- EN ISO11553-1:2016 Safety of machinery – Laser processing machines
- EN 60204-1:2011-01 Machine Safety – electr. Equipment
- EN 60825-1:2015-07, EN 60825-4:2011-12 Safety of Laser Equipment
- EN 61000-6-4:2011-09 Electromagnetic Compatibility

### **Place, Date:**

Wels, 7/15/2016

### **Personal data of the signer:**

Georg ERNST, Head of Research and Development

### **Signature:**



---



## Acceptance report

Dear customer!

We request your confirmation of properly completed transfer of the machine. Please transmit a copy of this document - filled out and signed by an authorized company representative - to an employee of our sales affiliate for forwarding to the manufacturer.

Please check applicable items:

- Machine parts checked for shipping damage.
- Machine parts checked against delivery note.
- Setup of the machine discussed.
- Startup of the machine discussed.
- Operation of the machine discussed.
- Maintenance of the machine discussed.
- Electrical voltage checked.
- Safety notes discussed.
- Trial run performed.
- Deficiencies determined.

The machine with the machine designation:

has been checked according to the listed items and has been handed over properly.

\_\_\_\_\_  
City, Date

\_\_\_\_\_  
(Instructed person)  
Name, Position

\_\_\_\_\_  
Company stamp, Signature

## Response form

Dear customer!

In case of any trouble with the machine, please provide the following information and additionally create a service file.

### Contact details

Name: \_\_\_\_\_  
Country: \_\_\_\_\_  
Phone: \_\_\_\_\_  
E-mail: \_\_\_\_\_  
Date: \_\_\_\_\_

### Machine data

Serial number: \_\_\_\_\_  
JobControl® version: \_\_\_\_\_  
Driver version: \_\_\_\_\_  
Layout Software: \_\_\_\_\_  
Firmware version: \_\_\_\_\_

Description of the problem

Does an error message show up on the PC , and if so, which?

What happened before the error occurred? (Thunder and lightning, Windows-Update...)

What attempts were made to solve the problem?

Please send the information to your sales representative, to your local support or to following e-mail address: [techsupport@troteclaser.com](mailto:techsupport@troteclaser.com).



## Training verification form

Trainee: \_\_\_\_\_

Trainer: \_\_\_\_\_

Date of Training: \_\_\_\_\_

The employee named above was instructed in the operation of the .....  
laser system. Especially the following topics were covered:

- Machine function
- Danger areas
- Warnings
- Position of the Emergency stop button
- Personal protective equipment
- Operating equipment
- Workflow
- Setting-up
- Startup and Shutdown
- Reporting of unexpected working results and actions to be taken.
- Reporting of failure and actions to be initiated.
- Responsibility for troubleshooting.
- Operating manual and it's storage location for inspection.

\_\_\_\_\_  
Signature Trainer

\_\_\_\_\_  
Signature Trainee